

# Datasheet

## VC-8000 Machinery Protection System

### Overview

The SETPOINT Machinery Protection System (model VC-8000) is a rack-based continuous machinery monitoring platform designed to fully comply with American Petroleum Institute Standard 670 for machinery protection systems. Up to 60 vibration/position/speed channels or 90 temperature/process variable channels can be monitored and displayed in a single 19" rack.

The system measures and alarms on a wide variety of vibration, position, speed, temperature, and process variable inputs (refer to page 9 for a comprehensive list). All necessary monitoring functionality is provided using only four basic module types, simplifying spare parts requirements.

A SETPOINT MPS consists of the following components:

- **Rack Chassis**

The rack chassis is available in 16-slot, 8-slot, and 4-slot sizes. 16-slot and 8-slot racks are available with an optional lockable faceplate and integral touchscreen display, while 4-slot racks are intended for blind (no display) or remote display applications only. Slot 1 in all racks is reserved for the Rack Connection Module (RCM). Slots 2 and 3 are available for System Access Modules (SAMs) or monitoring modules. Slots 4-16 are available for monitoring modules only. Racks may be mounted in a panel cutout, on 19" EIA rails (16-slot rack only), or with the back flush against a wall or surface (i.e., bulkhead mounting). The rack and its optional door/touchscreen can be mounted such that modules insert from the front (behind the door) or rear (side opposite the door). The rear-insertion option is particularly useful when retrofitting older monitoring systems where wiring lands on the back of the rack.



- **Rack Connection Module (RCM)**

This module accepts simplex or redundant +24Vdc power and distributes this power to all other installed modules via the rack backplane. It also accepts discrete inputs from external contact closures to invoke rack-wide functions including Alarm Reset, Bypass, Trip Multiply, and Special Alarm Inhibit. The system's Fault (NOT OK) Relay is contained in the RCM. One RCM must be installed in slot 1 of every rack.

A variation on the RCM called the Power Connection Module (PCM) is an optional accessory that may reside in any rack slot. It is used in conjunction with the RCM for redundant power schemes. The PCM is identical to the RCM, but has connections only for Power 1 (P1) and Power 2 (P2). The presence of both an RCM and a PCM in a rack allows either of these modules to be removed without interrupting rack power, providing the highest level of tolerance to single point failures. Refer to pages 31-32 of this datasheet for diagrams showing typical redundant power configurations.



- **System Access Module (SAM)**

This module provides four separate communications ports:

<b>DCS</b>	This 10/100 BASE-T Ethernet port uses MODBUS® TCP/IP protocol for connecting a SETPOINT system to a distributed control system (DCS) or other type of plant/machinery control or automation platform. This port supports static data only.
<b>DCS SER</b>	Identical to the DCS port, this additional port supports MODBUS® RTU (serial) communications using RS-232, RS-422, and RS-485.
<b>CMS</b>	This 10/100/1000 BASE-T Ethernet port streams data to SETPOINT CMS condition monitoring software. It supports both static and dynamic (waveform) data.
<b>Display</b>	This LVDS port is used when interfacing to the optional 8.4" color touchscreen.



Although the SAM is not part of the critical path for machinery protection, it is strongly recommended that all racks include at least one SAM (slot 2); an optional second SAM may be added in slot 3 when communication redundancy is required. Racks without a SAM may place a TMM or UMM in slot 2 to increase the total number of monitored channels. When the SAM's SD Card slot and optional solid-state hard drive are enabled for data storage, the same data as streamed from the CMS port can be retained in the rack for up to one full year.

- **Universal Monitoring Module (UMM)**

This 4-channel module provides all available measurements except temperature. Four programmable SPDT relays and four programmable 4-20 mA analog outputs are provided on each UMM. The module accepts a large variety of proximity, velocity, acceleration, pressure, process variable<sup>1</sup>, position, and discrete input signals. Two versions of the UMM are available: UMM and UMM<sub>CM</sub>. The UMM<sub>CM</sub> is identical to the UMM, but allows streaming of condition monitoring data to the CMS port on the rack's System Access Module



(SAM). Up to 15 UMMs may be installed in a single rack<sup>2</sup> (slots 2-16); they may be mixed in any combination with TMMs. Up to six<sup>3</sup> (6) shared phase triggers may be installed in a single SETPOINT rack for use by all other rack channels.

- **Temperature Monitoring Module (TMM)**

This 6-channel module provides configurable temperature and process variable measurements along with four programmable SPDT relays and six programmable 4-20 mA analog outputs. It accepts 2-, 3- and 4-wire RTDs, grounded / ungrounded thermocouples, and 4-20 mA process variable signals<sup>1</sup> in any combination. Two versions of the TMM are available: TMM and TMM<sub>CM</sub>. The TMM<sub>CM</sub> is identical to the TMM, but allows streaming of condition monitoring data to the CMS port on the rack's System Access Module (SAM). Up to 15 TMMs may be installed in a single rack (slots 2-16); they may be mixed in any combination with UMMs.



- **Rack Configuration Software**

This software allows configuration of all modules in a rack by connecting to the USB port on any UMM or TMM. A copy of this software is provided with each system free-of-charge. It can also be downloaded from our website.



**NOTES:**

1. TMMs accept only 4-20mA signal formats and do not provide loop power; UMMs accept a wider variety of process variable formats and also provide loop power.
2. A UMM in slot 2 is not able to supply its buffered output signals to the RCM connector or to programmable BNC connectors used with the touchscreen display. The RJ45 connector on the UMM front panel must be used instead.
3. Shared phase triggers available only on UMM channel 4, slots 4-9. 8-slot rack limited to 5 shared phase triggers; 4-slot rack limited to 1 shared phase trigger.

- **Integral Backlit Touchscreen Display**

Both half- and full-size racks can be ordered with an optional 8.4" color touchscreen display. The display mounts on the rack's lockable faceplate and provides all rack



statuses and channel values on a single screen. It also allows the user to access detailed channel data, the system events list, and the system alarm list (see pages 7-8 for screen captures and additional information). The display fully complies with API 670 requirements.

- **Remote Display Panel (RDP)**

The RDP is a rack faceplate with touchscreen and programmable BNC connectors, but without hinges and a keylock. It allows the display to be mounted up to 10' away from the rack chassis. Unlike the integral display, the remote display can be used with 4-P rack sizes, since the display is not mounted on the rack's faceplate. Refer to page 16 for ordering information and additional details.



- **Power Supplies**

The SETPOINT system is energized using standard +24 Vdc instrument power, readily available in many plants. In such installations, no external power supply is required. Simply connect one or two (when optional redundancy is required) 24 Vdc power source(s) to the Rack Connection Module (RCM). For installations with 110/220 Vac, 90-250 Vdc, 400 Vac 3-PH, or 500 Vac 3-PH power sources, an external power supply (EPS) is used. Each EPS is mounted via 35mm DIN rail external to the rack enclosure.



- **I.S. Barriers**

The SETPOINT system carries globally recognized hazardous area approvals, allowing the rack to be installed in Div 2 / Zone 2 areas without use of barriers. When transducers will be installed in Div 1 / Zone 1 areas, the SETPOINT system must be located in a safe area or a Div 2 / Zone 2 area. Intrinsic Safety (I.S.) barriers are then used to limit the available energy on the transducer signal and power connections. The SETPOINT system supports the use of both passive (zener) and active (isolated) barriers.

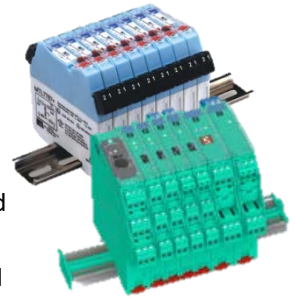

- **SETPOINT CMS Condition Monitoring Software**

The SETPOINT system offers two industry-first capabilities for condition monitoring and both can be used concurrently. The first is to stream all static and dynamic (waveform) data to a connected OSIsoft PI System where the data is archived. Trends, statuses, and other static data formats can then be viewed using standard PI visualization clients such as PI Vision and PI ProcessBook. Waveforms and specialized data presentation formats such as timebase, orbit, spectrum, polar, bode, shaft centerline, and others are viewed using our SETPOINT CMS Display software, a stand-alone application that can be tightly integrated with PI visualization clients.

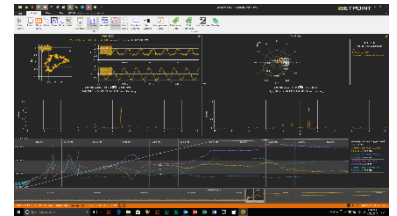

The second method is to store the condition monitoring data inside the SETPOINT rack itself on a removable 32GB SD Card and/or solid-state hard drive that can hold up to one full year of data. This data is identical to that streamed to a PI Server but is retrieved from the rack manually rather than via a network. It is visualized using the same SETPOINT CMS Display software as is used for viewing data when stored in PI.



## Features and Benefits

- **Integrated Condition Monitoring**

Condition monitoring data can be streamed to optional SETPOINT CMS software and/or to internal storage in the rack, eliminating the need for networks, servers, and IT infrastructure. Using an embedded solid-state hard drive or removable 32GB SD card, up to one full year of high-resolution data can be stored. This powerful capability turns a machinery protection system into a “flight data recorder” that ensure you will never again miss important data when a machine experiences problems.

- **Deep experience**

The SETPOINT team possesses deep experience gained through developing and sustaining more than four generations of successive API 670-compliant machinery protection systems. We pay attention to every detail, ensuring the system works the way you need it to work in the real world – where details matter.

- **Robust, rugged construction**

The SETPOINT rack chassis is constructed entirely of industrial-grade anodized aluminum and stainless steel – every card guide, every faceplate, every rack panel. In addition to excellent RFI/EMI rejection, these materials are built to last while maintaining their good looks. The SETPOINT system looks professional because it is professional.

- **Easily adaptable mounting**

The SETPOINT system’s design allows the same rack to be used in panel cutout, 19” EIA, or bulkhead mounting configurations by simply employing different rack brackets. The chassis, backplane, and all modules remain the same. This also means that you don’t sacrifice valuable space when bulkhead mounting – unlike systems that require twice as much space for bulkhead mounting compared to rack or panel mounting.

- **High-quality, high-speed backplane**

The SETPOINT system uses state-of-the-art backplane

connectors and a high-speed network architecture to facilitate ultra-fast data throughput and outstanding reliability.

- **Flexible front or back wiring**

The SETPOINT rack’s flexible design allows the chassis to face forward or backward. When facing forward, modules insert from the front and wiring lands on the front. When facing backward, modules insert from the back and wiring lands on the back. In either orientation, the optional touchscreen display can be mounted in a location convenient for the user, whether directly on the chassis, or up to 10 feet (3m) away. Front wiring is recommended for most installations and is the default configuration for all racks. It eliminates back-and-forth trips around the panel to access each side of the rack during installation and maintenance. Front loading neatly recesses all connections behind the SETPOINT system’s attractive, lockable faceplate, protecting your critical wiring while keeping it easily accessible.

- **Full-color, backlit touchscreen**

With the SETPOINT system’s optional touchscreen, users have at-a-glance, real time visibility of every channel and status in the rack on a single screen – no scrolling, no multiplexing. We worked closely with users to ensure the system’s display was intuitive, efficient, and attractive, with a rapid update time so there’s no annoying wait for the screen to refresh with current values. It’s also easy to see under varied lighting conditions. And, because it uses resistive (not capacitive) technology, it works with fingers, gloves, and stylus.

- **Lockable front faceplate**

Whether with or without the optional touchscreen display, every SETPOINT rack can be ordered with a lockable faceplate. It protects all installed wiring from tampering and provides physical security, preventing unauthorized personnel from accessing configuration and data ports. Its sleek, black painted finish is designed to complement any installation, whether in the control room or on the machine deck.

- **High-density design**

Systems that use separate modules for display

drivers, relays, phase triggers, power supplies, and Modbus communications can mean that only 40% of the rack's slots are actually available for vibration and temperature monitoring. In contrast, the SETPOINT system requires only two slots for system power and communications (including display) – all other slots are available for monitoring. Up to 60 vibration channels in a full-size 19" rack and up to 28 vibration channels in a half-size rack. No other system offers such efficient use of space.

- **No jumpers or DIP switches**

Every option in the SETPOINT system is configured via software. Cards do not have to be removed from the rack.

- **Hot swappable**

Modules can be inserted and removed without powering down the rack.

- **Flexible buffered output options**

The SETPOINT system delivers buffered transducer outputs at 3 different locations in the rack: at an RJ45 receptacle on each UMM where all 4 channels are available concurrently; at a 60-pin connector set on the RCM where 56 UMM channels are available concurrently; and, at 3 programmable BNC connectors on the front panel. By simply using the touchscreen, you can select 2 vibration channels and their associated phase trigger, easily switching channels without ever needing to move cables from one set of BNC connectors to the next. Imagine gathering 56 channels of dynamic data with your data collector without constantly disconnecting and reconnecting. And, we've taken the ambiguity out of these connections. When you select a channel via the touchscreen, it displays all details – channel tag and description, mV output in engineering units, and everything else necessary to ensure that your data collector inputs match the monitor system outputs.

- **Outstanding EMI/RFI performance**

Solid metal construction, EMI gaskets, state-of-the-art filtering, and international EMI/ RFI approvals mean that the SETPOINT system operates trouble-free in even the noisiest electromagnetic environments. CE mark is standard on all systems.

- **Clear, intuitive labeling**

Easily identify status LEDs and connections; wiring labels are provided on each module's faceplate and its removable connectors.

- **Programmable 4-20 mA outputs**

Each monitor module provides the same number of 4-20 mA outputs as channels. However, these outputs can be assigned to any channel in the module, and any measurement. For example, a 4-channel monitor can assign its direct measurement from each channel to a corresponding 4-20 mA output. Or, it can assign a channel's direct measurement to analog output 1, its 1X amplitude to analog output 2, its 1X phase to analog output 3, and its gap voltage to analog output 4. There are no restrictions as to measurement type or channel, provided the value originates on the same module as the 4-20mA output.

- **Up to 60 SPDT electro-mechanical relays**

With 15 available slots and 4 relays in every monitor module, separate relay modules are not required, allowing more efficient use of rack space. Relay voting logic and channel assignments are fully programmable, allowing channels and conditions on one card to drive relays on its own or separate cards.

- **Standard +24 Vdc instrument power**

Because standard +24 Vdc instrument power is readily available in many plants, the SETPOINT system accepts this voltage directly. Simply connect 24 volt power to the RCM on each rack. When 24V power is not readily available, a wide variety of external supplies are available to accept 110/220 Vac, 90-350 Vdc, and even 400/500 Vac 3-phase power. And because all power sources are located outside the rack, heat dissipation is kept outside the rack as well, resulting in a system that runs cooler and can use smaller enclosures.

- **Truly redundant supplies**

The SETPOINT rack accepts two independent 24 volt power sources and can be supplied with one or two rack modules that each accept redundant power, for both power redundancy and module redundancy. Via the backplane, both 24V power sources are available

to each and every module in the rack. The module in each slot individually determines the best available source. As soon as one source is removed (or its voltage drops below the other), all modules seamlessly switch to the alternate source assuring uninterrupted system operation.

- **Distributed power regulation**

Unlike systems that centrally regulate or condition incoming power and then distribute every voltage needed, each monitor in the SETPOINT system runs on 24 Vdc and creates its own regulated voltages. This design philosophy reduces the potential for rack single-point failures compared to systems that generate all regulated voltages centrally. In the SETPOINT system, regulator problems affect only a single module, not the entire rack.

- **Simplified spare parts**

Only four basic module types are used, regardless of transducer input types, output types, or system options. The Universal Monitoring Module performs all measurements except temperature, dramatically reducing spare parts requirements and associated costs.

- **Spreadsheet-like configuration environment**

SETPOINT software provides unparalleled ease of configuration – easily cut and paste data to/from Microsoft® Excel® and most other programs. No manual reentry of data from project datasheets and documents is required, reducing the likelihood of transcription errors and eliminating tedious typing to duplicate information that already exists electronically elsewhere.

- **Highly reliable architecture**

Monitor modules in the SETPOINT system use just three transitional connectors from signal input to relay output – significantly reducing possible failure points in the critical machinery protection path.

- **Integration with OSIsoft's PI® System software**

Our partnership with OSIsoft provides native connectivity between the SETPOINT system and the PI System. Full data trending, archiving, display, and analysis capabilities are available from data stored in

the PI database. Use PI ProcessBook to view basic system data such as trends and statuses; use SETPOINT CMS (which can be launched directly from ProcessBook) to view waveform data using a host of plot types such as orbit, spectrum, bode, shaft centerline, timebase, and more.

- **Digital MODBUS® communications**

Provides connectivity to virtually all machinery and process control system using this industry-standard protocol. Can be used in lieu of (or simultaneously with) analog 4-20 mA outputs on monitor modules for flexibility when integrating with other instrumentation.

- **Optional MODBUS redundancy**

Up to two SAM cards can reside in a single SETPOINT rack for redundant MODBUS communications links with distributed, plant, and machinery control systems.

- **SIL-Capable Architecture**

SETPOINT is suitable for use in SIL1, SIL2, and SIL3 safety instrumented functions when configured properly and with suitable sensor, monitor, and final element redundancy. It is one of the few vibration monitoring architectures on the market with the ability to meet SIL2 in a simplex configuration.

- **Highly Flexible Rack Control**

The UMM discrete channel type can be used not only to accept and display discrete on/off type signals, but to control rack states such as trip multiply, bypass, inhibit, etc. When invoked from the wiring terminals on the RCM, these control states are applied rack wide. When invoked using UMM discrete input channels, these states can be *individually* applied to user-configurable groups, facilitating better control when multiple machine trains are combined in a rack, each with its own unique trip multiply, bypass, inhibit, and other control needs.

- **No separate I/O modules required**

Module functions and I/O are contained on the same card.

## Typical Screens

### Machine-at-a-Glance Screen

Shows all channels in the rack (up to 84), arranged into user-configurable groups – typically trains, cases, and bearings. Bargraphs are color-coded to show alarm condition and normalized to % of danger setpoint for ease of comparison. Tap on any bargraph to obtain an inset screen showing additional channel detail. Selected bargraph turns blue for easy identification. Details window can be moved and pinned anywhere on screen.

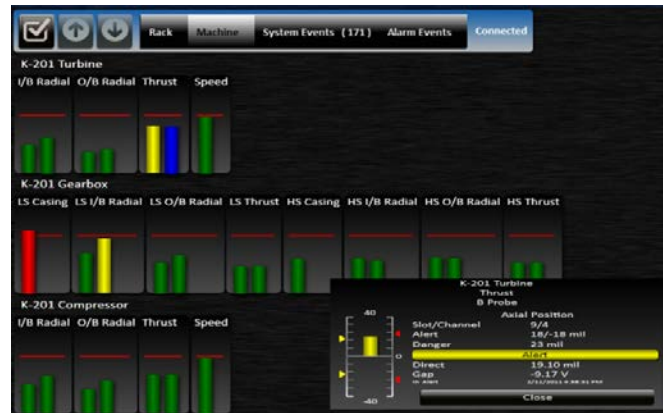

### Expanded Channel Details Screen

Is available by tapping on the detail inset screen. This expands to a full-screen view showing all measurements associated with the channel and their corresponding alarm setpoints. Most channel types can be configured to return multiple measurements such as overall amplitude, filtered amplitude in a variety of user-configurable bandpass regions, and sensor gap/bias voltage.

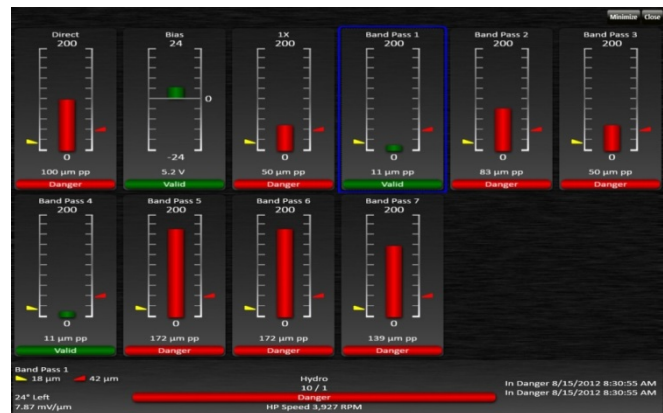

### Rack-at-a-Glance Screen

Is similar to machine-at-a-glance, but arranged by slot/channel to correspond with the physical configuration of the rack's slot and channel assignments. This view is especially useful for I&C personnel that need to work with the rack based on physical slot and channel assignments. This screen also shows the status of each relay in addition to the status of each channel. Tapping on a relay or bargraph opens a detail inset window.



### Tabular Bargraph Screen

Provides easy-to-see text values with current readings for each channel, along with color coding for alarm state. This view is particularly useful when the SETPOINT rack is located inside a weatherproof enclosure or behind a glass viewing door, allowing the primary (direct) values for all channels to be displayed without opening the enclosure / door to interact with the touchscreen.

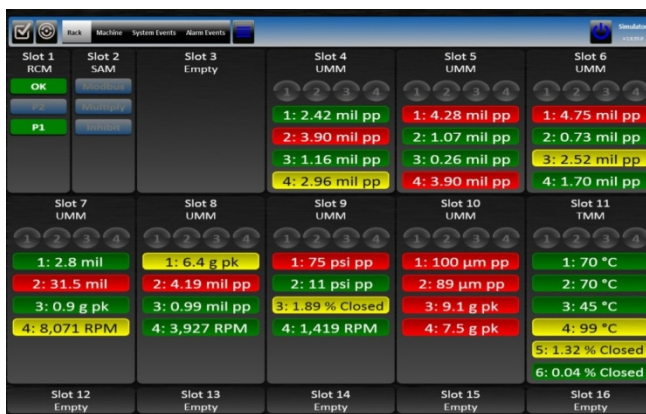

### System Events Screen

Arranges all system events in an intuitive spreadsheet-like fashion. Severity is clearly indicated by color-coded icons, and unacknowledged events are highlighted in bold. Users can sort the list by simply tapping on the column header. To scroll, use the up/down arrow icons on the top menu bar. To acknowledge events and alarms, tap the checkbox icon at the top of the screen.

Severity	Direction	Date Time	Event Type	Source	Channel Type
<input type="checkbox"/>	In	2/11/2011 5:11:17 PM	Inhibit Relay	...Y Probe	Radial Vibration
<input type="checkbox"/>	In	2/11/2011 5:11:17 PM	Special Alarm Inhibit	Metrix.Core.Domain.Module	
<input type="checkbox"/>	In	2/11/2011 5:11:16 PM	Module Removed From System	...Y Probe	Radial Vibration
<input type="checkbox"/>	In	2/11/2011 5:11:16 PM	Inhibit Relay	Metrix.Core.Domain.Module	
<input type="checkbox"/>	In	2/11/2011 5:11:15 PM	Special Alarm Inhibit	Metrix.Core.Domain.Module	
<input type="checkbox"/>	In	2/11/2011 5:11:15 PM	Relay Failure	Metrix.Core.Domain.Module	
<input type="checkbox"/>	In	2/11/2011 5:11:14 PM	Module Rebooted	Metrix.Core.Domain.Module	
<input type="checkbox"/>	In	2/11/2011 5:11:14 PM	Module Inserted Into System	Metrix.Core.Domain.Module	
<input type="checkbox"/>	In	2/11/2011 5:11:13 PM	Module Removed From System	...Phase Trigger	Phase Trigger
<input type="checkbox"/>	In	2/11/2011 5:11:13 PM	Module Not Communicating	Metrix.Core.Domain.Module	
<input type="checkbox"/>	In	2/11/2011 5:11:12 PM	Inhibit Relay	...Y Probe	Radial Vibration
<input type="checkbox"/>	In	2/11/2011 5:11:12 PM	Inhibit Alert	Metrix.Core.Domain.Module	
<input type="checkbox"/>	In	2/11/2011 5:11:10 PM	Relay Failure	...Accet	Acceleration
<input type="checkbox"/>	In	2/11/2011 5:11:10 PM	Special Alarm Inhibit	...Accet	Acceleration
<input type="checkbox"/>	In	2/11/2011 5:11:09 PM	Bypass Channel	...X Probe	Radial Vibration
<input type="checkbox"/>	In	2/11/2011 5:11:09 PM	Slot ID Failure	Metrix.Core.Domain.Module	
<input type="checkbox"/>	In	2/11/2011 5:11:08 PM	CM Processor Rebooted	Metrix.Core.Domain.Module	
<input type="checkbox"/>	In	2/11/2011 5:11:08 PM	Module Not Communicating	Metrix.Core.Domain.Module	

### Alarm Events Screen

Is similar to System Events Screen, but arranges all alarm events instead. Severity is clearly indicated by color-coded icons, and unacknowledged alarms are highlighted in bold. Users can sort the list by simply tapping on the column header. To scroll, use the up/down arrow icons on the top menu bar. To acknowledge events and alarms, tap the checkbox icon at the top of the screen.

Severity	Direction	Date Time	Event Type	Source	Channel Type
<input type="checkbox"/>	In	2/11/2011 5:13:05 PM	Alert	...VDirect	Acceleration
<input type="checkbox"/>	Out	2/11/2011 5:13:05 PM	Danger	...VDirect	Acceleration
<input type="checkbox"/>	In	2/11/2011 4:59:38 PM	Alert	...IDirect	Radial Vibration
<input type="checkbox"/>	In	2/11/2011 4:59:20 PM	Danger	...IDirect	Acceleration
<input type="checkbox"/>	In	2/11/2011 4:59:20 PM	Danger	...IDirect	Acceleration
<input type="checkbox"/>	In	2/11/2011 4:59:14 PM	Alert	...IDirect	Acceleration
<input type="checkbox"/>	In	2/11/2011 4:58:31 PM	Alert	...IDirect	Axial Position
<input type="checkbox"/>	In	2/11/2011 4:58:25 PM	Alert	...IDirect	Axial Position

### BNC Selection Screen

Racks with an optional touchscreen display come with three programmable BNC connectors directly beneath the touchscreen – two for channels and one for an associated phase trigger. To assign a particular channel’s output to a BNC connector, simply touch the BNC icon and then the desired channel. There is no need to move cable connections from one channel to the next. A pop-up window provides a wealth of information regarding the signal at each BNC connector, including channel name, transducer type, engineering units, scale factor, output impedance, transducer orientation, and more.





# Specifications

Specifications in this document are for rack chassis, system power, and touchscreen display only. For detailed specifications on each module type and selected accessories, refer to the following companion datasheets:

Components	Datasheet
SAM	1077786
UMM	1077787
TMM	1077788
RCM and External Power Supplies	1078950
Weatherproof Housings	1078951
SETPOINT CMS Software	1157533
Signal Simulator Interface	1095333

All specifications are at +25C (+77° F) unless otherwise noted.

Inputs			
<b>Number of Slots</b>	<ul style="list-style-type: none"> <li>Full Rack: 16</li> <li>Half Rack: 8</li> <li>Quarter Rack: 4</li> </ul>		
<b>Supported Module Types and Quantities</b>	<b>Module</b>	<b>Location</b>	<b>Max Qty</b>
	RCM	Slot 1	1
	SAM	Slots 2-3*	2*
	UMM	Slots 2-16	15
	TMM	Slots 2-16	15
* A second SAM may be installed in slot 3 if desired for redundant MODBUS communications. When a single SAM is installed, it must reside in slot #2.			
<b>Transducer Types</b>	<p><b>UMM</b></p> <ul style="list-style-type: none"> <li>Proximity Probes</li> <li>Proximity Switches (speed)</li> <li>Accelerometers</li> <li>Piezo and Moving Coil Velocity</li> <li>Magnetic Pickups (speed)</li> <li>Microphones</li> <li>Dynamic Pressure Sensors</li> <li>Discrete Inputs (dry contact, +3.3V logic, +5V logic)</li> <li>LVDTs (DC and 4-20mA)</li> <li>Process Variable Inputs - Externally or Internally Powered (+4 to +20mA, -4 to -20 mA, 0 to +5Vdc, +1 to +5Vdc, 0 to -10Vdc)</li> </ul> <p><b>TMM</b></p> <ul style="list-style-type: none"> <li>RTDs (2-, 3-, and 4-wire, platinum, copper, and nickel)</li> <li>Thermocouples (grounded and ungrounded tip, Type J,K,T,E)</li> </ul>		

	<ul style="list-style-type: none"> <li>Process Variable Inputs – Externally Powered Only (+4 to +20 mA and 0 to +1.5V)</li> </ul>
<b>Configurable Channel Types<sup>1</sup></b>	<p><b>UMM</b></p> <ul style="list-style-type: none"> <li>Acceleration – Standard</li> <li>Acceleration – Enveloped</li> <li>Acceleration – Aeroderivative</li> <li>Acceleration – Low Frequency</li> <li>Acceleration – REB (normal)</li> <li>Acceleration – REB (slow)</li> <li>Acoustic</li> <li>Axial Position (w/ or w/o PT)</li> <li>Case Expansion (single)</li> <li>Case Expansion (dual)<sup>2</sup></li> <li>Differential Expansion (DE)</li> <li>Complementary Input DE<sup>2</sup></li> <li>Ramp DE – single ramp<sup>2</sup></li> <li>Ramp DE – dual ramp<sup>2</sup></li> <li>Discrete Input (on/off)</li> <li>Dynamic Pressure</li> <li>Eccentricity</li> <li>Phase Trigger (PT) / Speed<sup>3,4</sup></li> <li>Plate Clash</li> <li>Process Variable – Enhanced<sup>6</sup></li> <li>Radial Vibration – Standard</li> <li>Radial Vibration – Hydro</li> <li>REBAM<sup>®</sup></li> <li>Recip – Impact</li> <li>Recip – Rod Drop</li> <li>Recip – Rod Position</li> <li>Recip – Crankcase Velocity</li> <li>Recip – Cylinder Pressure</li> <li>Reverse Rotation<sup>2</sup></li> <li>Rotor Acceleration<sup>4</sup></li> <li>Shaft Absolute – Radial Vib’n<sup>2</sup></li> <li>Shaft Absolute - Velocity<sup>2</sup></li> <li>Tachometer<sup>4</sup></li> <li>Valve Position</li> <li>Velocity – Standard</li> <li>Velocity – Aero Tracking</li> <li>Velocity – Aero Bandpass</li> <li>Velocity – Hydro</li> <li>Velocity – Low Frequency</li> <li>Zero Speed<sup>2</sup></li> </ul> <p><b>TMM</b></p> <ul style="list-style-type: none"> <li>Temperature<sup>5</sup></li> <li>Process Variable – Basic<sup>6</sup></li> </ul> <p><b>NOTES:</b></p> <ol style="list-style-type: none"> <li>Refer to datasheet 1077787 for details on measurements returned for each UMM channel type; refer to datasheet 1077788 for details on measurements returned for each TMM channel type.</li> </ol>

	<ol style="list-style-type: none"> <li>2. Measurement requires two channels.</li> <li>3. Shared phase triggers available only on UMM channel 4, slots 4-9. 8-slot rack limited to 5 shared phase triggers; 4-slot rack is limited to 1 shared phase trigger.</li> <li>4. Phase trigger channels return shaft rotative speed, peak speed, and rotor acceleration (speed rate of change).</li> <li>5. Temperature channels can return direct temperature, group average temperature, and/or differential with other channel or group. Refer to datasheet 1077788 for additional details.</li> <li>6. Enhanced process variable channels can provide loop power for the transmitter and can accept a variety of dc voltages or currents. Basic process variable channels accept only 4-20mA or 0-1.5V, require external loop power, and require a special external shunt termination resistor for 4-20mA inputs. Refer to datasheets 1077787 and 1077788 for additional details.</li> </ol>	
<b>Discrete Rack Control</b>	<p>Four connections supporting dry contact, 3.3V, or 5V logic are available via the RCM:</p> <ul style="list-style-type: none"> <li>• Alarm Reset (Acknowledge)*</li> <li>• Inhibit (Bypass)</li> <li>• Trip Multiply</li> <li>• Special Alarm Inhibit</li> </ul> <p>These can be invoked remotely by wiring suitable for analog control signals. Refer to RCM datasheet 1078950 for details.</p> <p>* NOTE: The Alarm Reset (Acknowledge) function is also available as a local pushbutton on the RCM faceplate.</p>	
<b>Number of Power Supplies</b>	Accepts up to two +24 Vdc independent power sources	
<b>Allowable Wiring Sizes</b>	<b>Connector</b>	<b>AWG</b>
	Power	12 – 22
	Rack Control	14 – 28
	Fault (OK) Relay	12 – 24
	Alarm Relays	16 – 28
	Analog Outputs	20 – 24
	Signal Inputs	16 – 28
<b>Connectors</b>	Removable, with positive retention	
<b>Reverse Polarity Protection</b>	Power inputs protected from continuous input polarity reversal.	
<b>Input Voltage</b>	<ul style="list-style-type: none"> <li>• Nominal: +24 Vdc</li> <li>• Continuous: + 22 to +30 Vdc</li> <li>• Transient (&lt; 1 sec) : +18 to + 36 Vdc</li> <li>• Ripple &lt; 100mV pk to pk</li> </ul>	

<b>Power Consumption</b>	<p>≤ 160W, &lt;8A when input power voltage is 22 to 26 Vdc.</p> <p>NOTE: Assumes fully loaded 16-position rack with display, redundant SAMs, all relays energized, all 4-20 mA outputs at full scale, and maximum transducer power requirements.</p>
<b>Power Input Fuse Rating</b>	10 A
<b>Ground Select</b>	<ul style="list-style-type: none"> <li>• System common tied to chassis ground (external jumper* installed)</li> <li>• System common isolated from chassis ground** (external jumper* removed)</li> </ul> <p>*Jumper is accessible from the front of the rack and may be installed on either the P1 or P2 removable wiring connectors on the RCM.</p> <p>** This configuration is commonly used for systems with IS barriers where a separate IS ground must be established.</p>
<b>Alarm Reset</b>	<p>Alarm conditions can be reset (i.e., acknowledged) in any of four ways:</p> <ol style="list-style-type: none"> <li>1. Via the local RESET pushbutton on the faceplate of the RCM*</li> <li>2. Via remote contact closure by shorting the RST and COM terminals together on the RCM*</li> <li>3. Via the optional touchscreen display*</li> <li>4. Via the MODBUS digital interface**</li> </ol> <p>* Provides global (rack-wide) reset / acknowledgement of all alarms.</p> <p>** Provides per-channel reset / acknowledgement of alarms.</p>
<b>Buffered Transducer Outputs</b>	
<b>Front Panel Programmable BNC connectors</b>	<b>Connector Qty / Type</b>
	Three BNC (female) connectors; programmable via touchscreen:
	<ul style="list-style-type: none"> <li>• <b>Connector A</b> can select from any* UMM speed / phase channel in the rack.</li> <li>• <b>Connector B</b> can select from any* UMM channel in the rack.</li> <li>• <b>Connector C</b> can select from any* UMM channel in the rack.</li> </ul>
	* Only UMM channels in slots 3-16 are available for assignment to BNC connectors.
	<b>Impedance</b>
	<ul style="list-style-type: none"> <li>• 550 Ω</li> </ul>
<b>Short-Circuit Protected</b>	<ul style="list-style-type: none"> <li>• Yes</li> </ul>

	<b>Signal Type</b> <ul style="list-style-type: none"> <li>Raw (unfiltered, no integration) transducer signal in mV/engineering units.</li> </ul>
<b>UMM</b>	<b>Channels</b> <ul style="list-style-type: none"> <li>All 4 UMM channels are available concurrently at the RJ45 connector on the UMM's faceplate. A special RJ45-to-4-BNC cable is available as an optional accessory (p/n 100431).</li> </ul>
	<b>Connector Type</b> <ul style="list-style-type: none"> <li>RJ45 receptacle</li> </ul>
	<b>Impedance</b> <ul style="list-style-type: none"> <li>550 Ω</li> </ul>
	<b>Short-Circuit Protected</b> <ul style="list-style-type: none"> <li>Yes</li> </ul>
	<b>Signal Type</b> <ul style="list-style-type: none"> <li>Raw (unfiltered, no integration) transducer signal in mV/engineering units.</li> </ul>
<b>RCM</b>	<b>Channels</b> 56 NOTE: Buffered outputs are only available from UMM channels (not TMM channels), and only from UMMs in slots 3-16. If a UMM is located in slot 2, its buffered outputs can only be accessed via the RJ45 connector on the UMM's face, not via the RCM connector or programmable BNC connectors.
	<b>Connector Qty / Type</b> Two Molex® Pico-Clasp® 30-pin receptacles, each with 28 buffered output channels. NOTE: Buffered outputs are also available on each UMM via an RJ45 connector with all 4 channels, and on the optional rack faceplate via 3 programmable BNC-type connectors.
	<b>Impedance</b> <ul style="list-style-type: none"> <li>550 Ω</li> </ul>
	<b>Short-Circuit Protected</b> <ul style="list-style-type: none"> <li>Yes</li> </ul>
	<b>Signal Type</b> <ul style="list-style-type: none"> <li>Raw (unfiltered, no integration) transducer signal in mV/engineering units.</li> </ul>
<b>Analog Outputs</b>	
<b>Alarm Relays</b>	Four per monitor module. Each UMM and TMM provides four SPDT relays that can be

	programmed for individual channels, or for logical voting among two or more monitor channels in any rack slot.
<b>Fault (NOT OK) Relay</b>	One per rack, located on the RCM. Refer to RCM datasheet for additional details.
<b>4-20 mA</b>	Programmable. One per channel for all UMM and TMM cards.
<b>Digital Outputs</b>	
<b>Modbus TCP/IP &amp; RTU</b>	10/100 BASE-T connector on SAM provides channel values, channel status conditions, and a variety of other data. Additional connector provides MODBUS via RS-232, RS-422, and RS-485. Refer to SAM datasheet for additional details.
<b>Condition Monitoring</b>	10/100/1000 BASE-T connector on SAM provides full static and dynamic (waveform) data using an open, published protocol. Refer to SAM datasheet for additional details.
<b>LEDs</b>	
<b>OK</b>	<ul style="list-style-type: none"> <li>Each TMM and UMM provides an OK LED indicating that no faults or NOT OK conditions are present within the module or any channel therein.</li> <li>Each SAM provides an OK LED indicating that no faults are present within the module.</li> <li>Each RCM provides an OK LED indicating rack-wide status; when lit, no faults or NOT OK conditions exist in any module or channel.</li> </ul>
<b>Relays</b>	<ul style="list-style-type: none"> <li>Each UMM and TMM provides 4 LEDs (one for each relay) indicating that the relay is being driven true (corresponding to the configured alarm logic for each relay)</li> </ul>
<b>Bypass</b>	<ul style="list-style-type: none"> <li>Each UMM and TMM provides an LED indicating that one or more channels are in a BYPASS condition.</li> </ul>
<b>Comms</b>	<ul style="list-style-type: none"> <li>Each SAM provides two LEDs for each of its Ethernet ports, indicating whether a connection is present and whether send/receive activity is occurring.</li> </ul>

	<ul style="list-style-type: none"> <li>Each SAM provides a DSP (display) LED, indicating whether a touchscreen display is detected.</li> <li>Each SAM provides a Trip Multiply LED, indicating whether Trip Multiply has been invoked for the entire rack or any rack channel.</li> </ul>
<b>Power</b>	<ul style="list-style-type: none"> <li>The RCM provides individual status LEDs for both Power 1 and Power 2 connections. When lit, power is detected and is within specifications.</li> </ul>
<b>Display</b>	
<b>Size</b>	8.4 inches (213 mm), measured diagonally
<b>Resolution</b>	800 x 600 (SVGA)
<b>Aspect Ratio</b>	4:3
<b>Brightness</b>	1200 cd/m <sup>2</sup>
<b>Backlight</b>	Rated for 70,000 hours (8 years) to one-half brightness.
<b>Technology</b>	Active TFT
<b>Touchscreen Type</b>	Resistive
<b>Color</b>	32-bit (True Color)
<b>Environment and Area Classification Rating</b>	Div 2 / Zone 2 (same as rack and all modules). Inclusion of touchscreen display does not de-rate rack environmental or area classification specifications.
<b>API 670 Compatible</b>	Yes. All status conditions and channels are indicated continuously on a single screen, without scrolling or multiplexing.
<b>Display Refresh</b>	Channel values and statuses are updated on the display once/sec.
<b>Max. Racks per display</b>	A maximum of one SETPOINT rack may be connected to each touchscreen display.
<b>Event List</b>	<ul style="list-style-type: none"> <li>Size: 1000 events</li> <li>Time/Date Stamp Resolution: 40 ms*</li> </ul>
<b>Alarm List</b>	<ul style="list-style-type: none"> <li>Size: 1000 alarms</li> <li>Time/Date Stamp Resolution: 40 ms*</li> </ul>

\*NOTE: The system time stamps alarms and events to 40ms resolution; however, the touchscreen displays this value to only the nearest second. Full 40ms timestamp resolution is available via SETPOINT CMS software (see datasheet 1157533)

<b>Environmental</b>	
<b>Operating Temperature</b>	-20C to +65C
<b>Storage Temperature</b>	-40C to +85C
<b>Operating Temp. Ramp</b>	Do not exceed 0.5C/minute
<b>Storage Temp. Ramp</b>	Do not exceed 10C/minute
<b>Humidity</b>	5% to 95%, non-condensing
<b>CE Mark Directive</b>	
<b>ESD</b>	<ul style="list-style-type: none"> <li>Contact: 6 kV*</li> <li>Air: 8 kV</li> </ul> * Criteria B
<b>Radiated EMI Susceptibility</b>	<ul style="list-style-type: none"> <li>80 – 1000 MHz: 20 V/m*</li> <li>1.4 – 2 GHz: 6 V/m*</li> <li>2 – 2.7 GHz: 3 V/m*</li> </ul> * Criteria A
<b>Magnetic Field</b>	30 A/m, Criteria A
<b>EFT Burst</b>	2 kV, Criteria B
<b>EFT Surge (Signal Lines, Power Line)</b>	2 kV line to ground, Criteria B
<b>Conducted RFI (Signal Lines, Power Lines)</b>	150 kHz to 80 MHz, Criteria A
<b>Conducted RF Common Mode Immunity (Signal Lines, Power Lines)</b>	<ul style="list-style-type: none"> <li>15 Hz – 150 Hz: 10 V*</li> <li>150 Hz – 1.5 kHz: 1V*</li> <li>1.5 kHz – 150 kHz: 10 V*</li> </ul> * Criteria A
<b>Radiated EMI Emissions</b>	30 dB $\mu$ V/m @ 30 m, 30 MHz – 1000 MHz, Class A
<b>Conducted Emission</b>	60 dB $\mu$ V/m @ 30 m, 0.5 MHz – 30 MHz, Class A
<b>AC Power Voltage Dip Immunity</b>	One-half period, 30% reduction, Criteria B
<b>AC Power Voltage Dip Interruption</b>	250 periods, 95% reduction, Criteria B
<b>DC Power Voltage Dip Immunity</b>	10 ms, 60% reduction, Criteria B
<b>DC Power Voltage Dip Interruption</b>	30 ms, 100% reduction, Criteria B
<b>Low Voltage Directive</b>	Council Directive 2006/95/EC Low voltage using SETPOINT-supplied power supply (rack ordering option –CC) or other Low Voltage Directive approved supply.

## Hazardous Area Approvals



ATEX: (Ex) II 3 G Ex nA nC IIC 160°C(T3) Gc; ITS13ATEX47917X;  
IECEX: Ex nA nC IIC 160°C(T3) Gc; IECEX ETL 13.0041X;



**CONTROL NUMBER** 4006789  
 US: Class I, Zone 2, AEx nA nC IIC T4 Gc;  
 Class I, Division 2, Groups A, B, C, D, T4;  
 CANADA: Class I, Zone 2, Ex nA nC IIC T4 Gc;  
 Class I, Division 2, Groups A, B, C, D, T4;



Input:  $V_{MIN} = 18V$ ;  $V_{MAX} = 36V$ ;  $P_{MAX} = 160W$  ---  
 See User Manual  
 Operating Temp.:  $-20^{\circ}C \leq T_A \leq 65^{\circ}C$   
 Relay:  $V_{MAX} = 30VDC$ ;  $I_{MAX} = 5A$



CU: 2Ex nA nC IIC T3 Gc X;  
 RU C-US.ГБ08.В.00474

## Physical

<b>Dimensions</b>	See pages 20-21	
<b>Weight</b>	<b>Empty Rack Chassis*</b>	
	Full-size: 7.2 kg (15.9 lbs) Half-size: 4.8 kg (10.6 lbs) Quarter-size: 2.4 kg (5.3 lbs) * Includes 3" brackets, no faceplate, no display, no modules, no blank covers for unused module slots. Quarter-size rack not available with lockable faceplate/integral display. Must use Remote Display Panel (VC-8000/RDP) instead.	
	<b>Lockable Faceplate w/o display</b>	
	Full-size: 1.5 kg (3.3 lbs) Half-Size: 895 g (2 lbs)	
	<b>Lockable Faceplate w/ display*</b>	
	Full-size: 2.1 kg (4.7 lbs) Half-size: 1.5 kg (3.3 lbs) *Also reflects weight of Remote Display Panel (RDP).	
	<b>Recessed mounting bracket</b>	
	190 g (6.5 oz)	
	<b>Flush mounting bracket*</b>	
	80 g (3 oz) * Used for bulkhead and flush mounting.	
<b>Blank Slot Cover Plate</b>		
48 g (1.7 oz)		
<b>Shock</b>	IEC 68-2-27, Ea	15 g for 11 ms
<b>Vibration</b>	IEC 68-2-6	10 – 55 Hz, 0.75 mm 55 - 500 Hz, 2 g

### Safety Integrity Level (SIL) Capability

SETPOINT is suitable for use as part of SIL1, SIL2, and SIL3 safety instrumented functions when configured properly and with suitable sensor, monitor, and final element redundancy. Refer to SETPOINT Functional Safety Assessment (doc 1354794) for additional details.

## Ordering Information

### SETPOINT Monitoring System

Use the part number on pages 14-15 when ordering a complete SETPOINT system with all modules pre-installed in the correct rack slots. The part number and all dash numbers (AA-VV) will uniquely specify all system details including rack size, mounting type, module type for each slot, optional simplex or dual-redundant external power supplies, optional lockable faceplate, and optional touchscreen display.

When using a Remote Display Panel (RDP), the rack may be ordered with or without a door, but no display. The rack must also contain an eSAM to drive the display. Specify the RDP as a separate line item, using the ordering information on page 16.

Weatherproof housings are available separately. Refer to datasheet 1078951.

When spare modules are required, refer to page 19, (or the module-specific datasheet) for ordering information.

When a PCM will be installed in the rack in addition to the RCM in slot 1, the PCM must be ordered separately per the information on page 16. It can be installed in any empty rack slot 2-16.



### Caution

Monitor system modules are shipped with default factory configuration settings which are not necessarily suitable for any particular application. Before use, each module and channel must be configured properly for its application via SETPOINT configuration software. This software is included at no cost with each system or module ordered and is also available for download from our website.

**VC-8000/RCK-AA-BB-CC-DD-EE-FF-GG-HH-JJ-KK-LL-MM-NN-PP-RR-SS-TT-UU-VV<sup>1</sup>**  
**SETPOINT Machinery Protection System**

**AA**   **Mounting Style**

0	1	Panel Cutout, modules insert from front
0	2	Bulkhead, modules insert from front
0	3	19" EIA, modules insert from front
1	1	Panel Cutout, modules insert from rear
1	3	19" EIA, modules insert from rear

**BB**   **Slots / Faceplate / Display<sup>2</sup>**

0	1	8-slot, no faceplate, no display
0	2	16-slot, no faceplate, no display
0	3	8-slot, with faceplate, no display
0	4	16-slot, with faceplate, no display
0	5	8-slot, with faceplate and display <sup>3</sup>
0	6	16-slot, with faceplate and display <sup>3</sup>
1	1	4-slot, no faceplate, no display

**CC** **Power<sup>3,4</sup>**

0	0	+24 Vdc (no external supplies)
0	1	One 110/220Vac 50/60Hz supply, 360W
0	2	Two 110/220Vac 50/60Hz supplies, 360W
0	3	One 360-440 Vac (3φ) supply, 480W
0	4	Two 360-440 Vac (3φ) supplies, 480W
0	5	One 410-550 Vac (3φ) supply, 480W
0	6	Two 410-550 Vac (3φ) supplies, 480W
0	7	One 90-250 Vdc & 110/220 Vac supply, 240W
0	8	Two 90-250 Vdc & 110/220 Vac supply, 240W
0	9	One 110/220Vac 50/60Hz supply, 180W
1	0	Two 110/220Vac 50/60Hz supplies, 180W
1	1	One 110/220Vac 50/60Hz supply, 90W
1	2	Two 110/220Vac 50/60Hz supplies, 90W
1	3	One 90-250 Vdc & 110/220 Vac supply, 120W
1	4	Two 90-250 Vdc & 110/220 Vac supply, 120W

**DD**   **Approvals**

0	0	None
0	5	Multi (ATEX, IEC, ETLc)
X	X	Country-specific <sup>5</sup>

**EE**   **Slots 1 and 2**

0	0	RCM slot 1, no module slot 2
0	1	RCM slot 1, Basic SAM (bSAM) slot 2
0	2	RCM slot 1, Enhanced SAM (eSAM) slot 2
0	3	RCM slot 1, UMM slot 2
0	4	RCM slot 1, TMM slot 2
3	1	RCM slot 1, eSAM slot 2, CMS <sub>SD</sub>
3	2	RCM slot 1, eSAM slot 2, CMS <sub>SD</sub> and CMS <sub>HD32</sub>
3	3	RCM slot 1, eSAM slot 2, CMS <sub>SD</sub> and CMS <sub>HD256</sub>

**FF**   **Slot 3**

0	0	No Module Installed
0	1	Basic SAM (bSAM)
0	2	Enhanced SAM (eSAM)
0	3	UMM
0	4	TMM

0	5	UMM <sub>CM</sub> (Condition Monitoring enabled)
0	6	TMM <sub>CM</sub> (Condition Monitoring enabled)
3	1	eSAM with CMS <sub>SD</sub>
3	2	eSAM with CMS <sub>SD</sub> and CMS <sub>HD32</sub>
3	3	eSAM with CMS <sub>SD</sub> and CMS <sub>HD256</sub>

**GG**   **Slot 4**

0	0	No Module Installed
0	3	UMM
0	4	TMM
0	5	UMM <sub>CM</sub> (Condition Monitoring enabled)
0	6	TMM <sub>CM</sub> (Condition Monitoring enabled)

**HH**   **Slot 5**

0	0	No Module Installed
0	3	UMM
0	4	TMM
0	5	UMM <sub>CM</sub> (Condition Monitoring enabled)
0	6	TMM <sub>CM</sub> (Condition Monitoring enabled)

**JJ**   **Slot 6**

0	0	No Module Installed
0	3	UMM
0	4	TMM
0	5	UMM <sub>CM</sub> (Condition Monitoring enabled)
0	6	TMM <sub>CM</sub> (Condition Monitoring enabled)

**KK**   **Slot 7**

0	0	No Module Installed
0	3	UMM
0	4	TMM
0	5	UMM <sub>CM</sub> (Condition Monitoring enabled)
0	6	TMM <sub>CM</sub> (Condition Monitoring enabled)

**LL**   **Slot 8**

0	0	No Module Installed
0	3	UMM
0	4	TMM
0	5	UMM <sub>CM</sub> (Condition Monitoring enabled)
0	6	TMM <sub>CM</sub> (Condition Monitoring enabled)

**MM**   **Slot 9**

0	0	No Module Installed
0	3	UMM
0	4	TMM
0	5	UMM <sub>CM</sub> (Condition Monitoring enabled)
0	6	TMM <sub>CM</sub> (Condition Monitoring enabled)

**NN**   **Slot 10**

0	0	No Module Installed
0	3	UMM
0	4	TMM
0	5	UMM <sub>CM</sub> (Condition Monitoring enabled)
0	6	TMM <sub>CM</sub> (Condition Monitoring enabled)

**PP**   **Slot 11**

0	0	No Module Installed
0	3	UMM

0 4	TMM
0 5	UMM <sub>CM</sub> (Condition Monitoring enabled)
0 6	TMM <sub>CM</sub> (Condition Monitoring enabled)

RR  Slot 12

0 0	No Module Installed
0 3	UMM
0 4	TMM
0 5	UMM <sub>CM</sub> (Condition Monitoring enabled)
0 6	TMM <sub>CM</sub> (Condition Monitoring enabled)

SS  Slot 13

0 0	No Module Installed
0 3	UMM
0 4	TMM
0 5	UMM <sub>CM</sub> (Condition Monitoring enabled)
0 6	TMM <sub>CM</sub> (Condition Monitoring enabled)

TT  Slot 14

0 0	No Module Installed
0 3	UMM
0 4	TMM
0 5	UMM <sub>CM</sub> (Condition Monitoring enabled)
0 6	TMM <sub>CM</sub> (Condition Monitoring enabled)

UU  Slot 15

0 0	No Module Installed
0 3	UMM
0 4	TMM
0 5	UMM <sub>CM</sub> (Condition Monitoring enabled)
0 6	TMM <sub>CM</sub> (Condition Monitoring enabled)

VV  Slot 16

0 0	No Module Installed
0 3	UMM
0 4	TMM
0 5	UMM <sub>CM</sub> (Condition Monitoring enabled)
0 6	TMM <sub>CM</sub> (Condition Monitoring enabled)

VC-8000/RCK NOTES:

1. To prevent ambiguity, the letters I, O, and Q are not used in SETPOINT part numbers.
2. When a touchscreen display is installed, an Enhanced SAM must be selected for slot 2 (EE=02).
3. When dual external power supplies are required and each will use a different voltage, order a system with a simplex power supply for one of the required voltages. Order the other external supply using the part numbers on page 17 of this datasheet.
4. 360W supply is stocked standard. Other supplies may incur longer lead times. Consult factory.
5. Country-specific approvals can be quoted upon request. Consult factory.

## Accessories

### Weatherproof Housing (WPH)

Painted (NEMA 4) or stainless steel (NEMA 4X) housings with lockable doors and viewing windows are available for all SETPOINT rack sizes.<sup>1</sup> The housings provide protection from dust moisture, and corrosion<sup>2</sup> when racks are mounted at the machine deck or in other industrial environments not suited for unprotected instrumentation. A complete housing accommodates a rack and its power supplies on an included DIN rail. When only a weatherproof door is required, it can be ordered as a kit without the complete housing. Door kits fit over face of racks mounted in panel cutouts, providing environmental seal against dust and moisture. Refer to datasheet 1078951 for specifications, drawings, and additional details.



**VC-8000/WPH-AA-BB-CC**

**SETPOINT Rack Weatherproof Housing**

AA  Type / Environmental Rating

0 1	11" Enclosure, Solid Door / NEMA 4
0 2	18" Enclosure, Solid Door / NEMA 4
0 3	24" Enclosure, Solid Door / NEMA 4
1 2	18" Enclosure, Window Door / NEMA 4
1 3	24" Enclosure, Window Door / NEMA 4
2 1	11" Enclosure, Solid Door / NEMA 4X <sup>3</sup>
2 2	18" Enclosure, Solid Door / NEMA 4X
2 3	24" Enclosure, Solid Door / NEMA 4X
3 2	18" Enclosure, Window Door / NEMA 4X <sup>3</sup>
3 3	24" Enclosure, Window Door / NEMA 4X <sup>3</sup>
5 2	18" Door Kit, Window / NEMA 4
5 3	24" Door Kit, Window / NEMA 4
7 2	18" Door Kit, Window / NEMA 4X
7 3	24" Door Kit, Window / NEMA 4X

BB  Conduit Fittings

0 0	No conduit hubs included
0 1	Four 1-1/4" NPT weatherproof conduit hubs

CC  Purge Fittings<sup>4</sup>

0 0	No purge fittings included
-----	----------------------------

DD  Agency Approvals

0 0	None
-----	------

### Power Supply Housing (PSH)

Accommodates up to two 360W DIN-rail mounted power supplies. Available only with a solid-door and used when the rack will be mounted in a WPH enclosure (see page 15) and either the WPH lacks sufficient room, or it is desirable to mount power supplies in a separate enclosure for thermal considerations. Refer to datasheet 1078951 for specifications, drawings, and additional details.



### Remote Display Panel (RDP)

The Remote Display Panel (RDP) is used when the touchscreen display will be mounted up to 10 feet away from the rack. The RDP mounts in a rectangular panel cutout and is secured using four screws. Identical to the rack's integral display, it is essentially a door/display assembly, but without hinges or a keylock. The RDP must be ordered as a separate line item from the rack, using the configuration options below. When specifying an RDP, order the SETPOINT rack with or without a faceplate, but no integral display.<sup>1</sup>



#### VC-8000/PSH-AA-BB-CC

##### SETPOINT Power Supply Housing

<b>AA</b>	<input type="checkbox"/>	<input type="checkbox"/>	<b>Type / Environmental Rating</b>
	0	1	12" x 12" x 6" Enclosure, Solid Door / NEMA 4
	2	1	12" x 12" x 6" Enclosure, Solid Door / NEMA 4X <sup>3</sup>
<b>BB</b>	<input type="checkbox"/>	<input type="checkbox"/>	<b>Conduit Fittings</b>
	0	0	No conduit hubs included
	0	1	Four 1-1/4" NPT weatherproof conduit hubs
<b>CC</b>	<input type="checkbox"/>	<input type="checkbox"/>	<b>Purge Fittings<sup>4</sup></b>
	0	0	No purge fittings included
<b>DD</b>	<input type="checkbox"/>	<input type="checkbox"/>	<b>Agency Approvals</b>
	0	0	None

#### VC-8000/WPH and VC-8000/PSH NOTES:

1. Window not available with 4-P rack size (11" housing width).
2. Specify NEMA 4X (stainless steel) housing when corrosion resistance required.
3. Stock standard item. Other sizes/ratings may incur longer lead times. Consult factory.
4. Purge fitting option not yet available.

### Power Connection Module (PCM)

Refer to pages 1 and 30-32 for a description and diagrams of the PCM. Unlike an RCM, a PCM does not come pre-installed in the rack. Order separately using the information below and allocate one empty slot in the rack to accommodate the PCM.



#### VC-8000/PCM-AA

##### Power Connection Module

<b>AA</b>	<input type="checkbox"/>	<input type="checkbox"/>	<b>Agency Approvals</b>
	0	0	No Approvals
	0	5	Multiple Approvals (pending)

#### VC-8000/RDP-AA-BB-CCC-DD

##### SETPOINT Remote Display Panel

<b>AA</b>	<input type="checkbox"/>	<input type="checkbox"/>	<b>Panel Size</b>	
	0	1	11" Panel	
	0	2	19" Panel	
<b>BB</b>	<input type="checkbox"/>	<input type="checkbox"/>	<b>Mounting Style</b>	
	0	1	Panel Mount	
	0	2	Retrofit Kit for Rack Face Mounting <sup>1,2</sup>	
<b>CCC</b>	<input type="checkbox"/>	<input type="checkbox"/>	<input type="checkbox"/>	<b>Display Cable<sup>3</sup></b>
	0	0	0	No cable supplied
	0	0	8	7.7" cable supplied <sup>4</sup>
	0	3	6	36" cable supplied <sup>5</sup>
	0	6	0	60" cable supplied
	0	8	4	84" cable supplied
	1	2	0	120" cable supplied
<b>DD</b>	<input type="checkbox"/>	<input type="checkbox"/>	<input type="checkbox"/>	<b>Approvals</b>
	0	0		None
	0	5		Multi (ATEX, IEC, ETLc)
	X	X		Country-specific

#### VC-8000/RDP NOTES:

1. At least one eSAM (ordered separately) must be installed in the rack, allowing communications with the RDP.
2. Retrofit Kit contains panel with hinges/keylock allowing field retrofit to rack face on systems originally supplied without a display.
3. Use of standard lengths offered here are encouraged. Cable lengths other than those shown can be provided as engineering specials, but are not stock standard and may incur long lead times. Consult the factory.
4. Use the 7.7" cable when BB=02 and the display will be mounted on the same side of the rack as module insertion.
5. Use the 36" cable when BB=02 and the display will be mounted on the opposite side of the rack from module insertion.



## External Power Supplies

When ordering power supplies as part of a system, specifying using option CC (see page 14). Use the part numbers below only when ordering spare power supplies, or when the second power supply in redundant configurations will use a different input voltage than the primary supply. 360W supplies are stock standard; others may incur longer lead times. Consult factory.



**100411<sup>1,3</sup>**  
110/220 VAC, 50/60 Hz, 360W Power Supply

**100414<sup>1,3</sup>**  
360-440 3Ø VAC, 50/60Hz, 480W Power Supply

**100416<sup>1,3</sup>**  
450-550 3Ø VAC, 50/60Hz, 480W Power Supply

**100417<sup>2,3</sup> and 100417A<sup>2,3,7</sup>**  
110/220 VAC & 90-250 VDC, 240W Power Supply

**100546<sup>1,4</sup>**  
110/220 VAC, 50/60 Hz, 180W Power Supply

**100547<sup>1,5</sup>**  
110/220 VAC, 50/60 Hz, 90W Power Supply

**100548<sup>2,4</sup> and 100548A<sup>2,6</sup>**  
110/220 VAC & 90-250 VDC, 120W Power Supply

### EXTERNAL POWER SUPPLY NOTES:

- Manufactured by TRACO or Wiedmuller; comes with following multiple approvals as standard:  
CSA Cl I, Div 2, Grps A-D; Cl I, Zone 2, Ex nC IIC T4 | CE  
ATEX II 3G Eex nAC IIC T4 | IEC/EN Cl I, Zone 2, Eex nC II C T4 U
- Manufactured by PHOENIX CONTACT. Comes with following multiple approvals as standard:  
UL/c-UL Recognized UL 1604 Class I, Div 2, Grps A-D  
ATEX II 3G Eex nAC IIC T4 | CE
- Compatible with all VC-8000 rack sizes
- Compatible with 4-P and 8-P racks only
- Compatible with 4-P racks only
- Identical to 100548, but no approvals and no conformal coating
- Identical to 100417, but no approvals and no conformal coating

## Breakout Cable<sup>1</sup>

This cable is used when connecting the channels in a single UMM to an external device such as a portable data collector with female BNC jacks. When it is necessary to simultaneously connect channels from multiple UMMs to external instruments, use two or more breakout cables. For ease-of-identification, each BNC connector is numbered under a clear heat-shrink label, corresponding to each UMM channel number. When longer cable runs are required, simply purchase standard CAT5E cable in the desired length and use an RJ45-to-RJ45 inline connector. Both are readily available from a variety of electronics suppliers.



**100431-AA**  
BNC breakout cable assembly – RJ45 (male) to four BNC (male)

AA   Cable Length

1  0 | 10 foot (3 m) cable length

### BREAKOUT CABLE NOTE:

- For systems with programmable BNC jacks on the SETPOINT faceplate, this cable is not required unless simultaneously connecting more than 3 channels to an external instrument.

## System Power Cable

This cable is used to connect 24Vdc power from an external source to the P1 or P2 connectors on the RCM. One end of the cable is pre-wired to the RCM mating connector and the other end has no connector installed, allowing it to be trimmed to length in the field. Cable is a shielded twisted pair (black = COM, red = +24 Vdc) with drain wire. A separate conductor (green) is provided for connection of chassis ground. All conductors are 12 AWG. A jumper is installed in the RCM connector tying COM to chassis ground. It may be removed for installations in which chassis ground and COM must be at different potentials (e.g., intrinsically safe installations).



**100435-AA**  
System Power Cable

AA   Cable Length

1  0 | 10 foot (3 m) cable length

### SAM-to-Display Cable

This cable connects a rack's touchscreen display to its associated eSAM. When the display is mounted on the face of the rack, a 7.7" cable length is used. When the remote display (VC-8000/RDP) is used, cable lengths of up to 10 feet are supported. Identical male connectors are preinstalled at each end, compatible with the female connectors at the SAM and the touchscreen. The connectors snap securely into place using integral locking mechanisms. This cable does not need to be ordered separately and is included automatically with all racks ordered with a local or remote touchscreen. Use the above part number only when ordering spare or replacement cables.



#### 100410-AAA SAM-to-Display Cable

AAA			Cable Length
0	0	8	7.7 inch length
0	3	6	36 inch length
0	6	0	60 inch length
0	8	4	84 inch length
1	2	0	120" length

### Recessed Mounting Brackets

These brackets are used whenever a door is supplied (VC-8000/RCK option BB = 03, 04, 05, or 06). They position the door 3" from the rack face, whether the modules will insert forward or backwards (AA=11 or 13). Normally, the brackets do not need to be ordered separately as they are included with each system based on the mounting option chosen. Use the part number below only when replacing lost or damaged brackets. These brackets are not ambidextrous and must be ordered individually by specifying right- or left-side.



#### 100375-A SETPOINT Recessed Rack Mounting Bracket

A		Bracket Location
L		Left-side Bracket
R		Right-side Bracket

### Flush Mounting Brackets

These brackets align the front of the rack with the face of the bracket and are intended only when mounting the rack without a faceplate,\* or when bulkhead mounting. Normally, the brackets do not need to be ordered separately as they are included with each system based on the mounting option chosen. Two of these brackets are supplied with each system using bulkhead mounting. Two are also supplied with all systems ordered without a faceplate, regardless of mounting option. The brackets mount on the rear of the rack when bulkhead mounting and on the front of the rack when flush mounting in a panel cutout or on 19" EIA rails. Use the part number below only when replacing a lost or damaged bracket, or when changing and existing rack to bulkhead mounting. The bracket is ambidextrous, and may be used on left, right, front, or rear of the rack.



#### 100384\*\* SETPOINT Flush Rack Mounting Bracket

\* When observing minimum bend radius for cables, wiring will typically protrude 2 inches (51 mm) beyond the face of rack modules. When the wiring should not protrude beyond the bracket face, use recessed brackets instead.

\*\* Flush brackets are supplied individually (not as a set of two).

### Manuals and Software

A complete set of SETPOINT manuals and configuration software on USB memory stick is supplied at no extra charge with each order, but must be specified at time of ordering. As languages in addition to English become available, they will be included on the memory stick. The most recent version of manuals and software can be downloaded directly from our website.

**NOTE:** Manuals are published electronically in Adobe® PDF\* format and may be printed and freely distributed. Adobe Reader is required and can be downloaded free-of-charge from [www.adobe.com](http://www.adobe.com). Hardcopy versions of manuals are also available from the factory for an additional charge.



#### VC-8000/CSW-AA SETPOINT Manual and Configuration Software

AA		Format
0	1	USB Memory Stick

### USB Cable

This cable is used to connect a computer running SETPOINT Configuration Software to the USB port on UMM and TMM modules. The cable is included with part number VC-8000/CSW and does not need to be ordered separately. Order the item below only when replacing a lost or damaged cable.



<b>96014-012</b>
<b>2m (6') USB 2.0 A / Mini-B Cable</b>

## Spares

### Rack Connection Module (RCM)

<b>VC-8000/RCM-AA</b>			
<b>Rack Connection Module (spare)</b>			
<b>AA</b> <input type="checkbox"/> <input type="checkbox"/> <b>Agency Approvals</b>			
<table border="1"><tr><td>0</td><td>5</td><td>Multi (ATEX, IEC, ETLc)</td></tr></table>	0	5	Multi (ATEX, IEC, ETLc)
0	5	Multi (ATEX, IEC, ETLc)	



### System Access Module (SAM)

<b>VC-8000/SAM-AA-BB</b>															
<b>System Access Module (spare)</b>															
<b>AA</b> <input type="checkbox"/> <input type="checkbox"/> <b>Type</b>															
<table border="1"><tr><td>0</td><td>1</td><td>bSAM (basic SAM)</td></tr><tr><td>0</td><td>2</td><td>eSAM (enhanced SAM with additional processor board to support dynamic data capture and optional touchscreen display)</td></tr><tr><td>3</td><td>1</td><td>eSAM with CMS<sub>SD</sub></td></tr><tr><td>3</td><td>2</td><td>eSAM with CMS<sub>SD</sub> and CMS<sub>HD32</sub></td></tr><tr><td>3</td><td>3</td><td>eSAM with CMS<sub>SD</sub> and CMS<sub>HD256</sub></td></tr></table>	0	1	bSAM (basic SAM)	0	2	eSAM (enhanced SAM with additional processor board to support dynamic data capture and optional touchscreen display)	3	1	eSAM with CMS <sub>SD</sub>	3	2	eSAM with CMS <sub>SD</sub> and CMS <sub>HD32</sub>	3	3	eSAM with CMS <sub>SD</sub> and CMS <sub>HD256</sub>
0	1	bSAM (basic SAM)													
0	2	eSAM (enhanced SAM with additional processor board to support dynamic data capture and optional touchscreen display)													
3	1	eSAM with CMS <sub>SD</sub>													
3	2	eSAM with CMS <sub>SD</sub> and CMS <sub>HD32</sub>													
3	3	eSAM with CMS <sub>SD</sub> and CMS <sub>HD256</sub>													
<b>BB</b> <input type="checkbox"/> <input type="checkbox"/> <b>Agency Approvals</b>															
<table border="1"><tr><td>0</td><td>5</td><td>Multi (ATEX, IEC, ETLc)</td></tr></table>	0	5	Multi (ATEX, IEC, ETLc)												
0	5	Multi (ATEX, IEC, ETLc)													



### Universal Monitoring Module (UMM)

<b>VC-8000/UMM-AA-BB</b>									
<b>Universal Monitoring Module (spare)</b>									
<b>AA</b> <input type="checkbox"/> <input type="checkbox"/> <b>Type</b>									
<table border="1"><tr><td>0</td><td>0</td><td>UMM</td></tr><tr><td>0</td><td>1</td><td>UMM<sub>CM</sub> (Condition Monitoring Enabled)</td></tr><tr><td>0</td><td>2</td><td>UMM<sub>CM</sub> (License Only)<sup>1</sup></td></tr></table>	0	0	UMM	0	1	UMM <sub>CM</sub> (Condition Monitoring Enabled)	0	2	UMM <sub>CM</sub> (License Only) <sup>1</sup>
0	0	UMM							
0	1	UMM <sub>CM</sub> (Condition Monitoring Enabled)							
0	2	UMM <sub>CM</sub> (License Only) <sup>1</sup>							
<b>BB</b> <input type="checkbox"/> <input type="checkbox"/> <b>Agency Approvals</b>									
<table border="1"><tr><td>0</td><td>0</td><td>Not Applicable (use only when AA=02)<sup>2</sup></td></tr><tr><td>0</td><td>5</td><td>Multi (ATEX, IEC, ETLc)</td></tr></table>	0	0	Not Applicable (use only when AA=02) <sup>2</sup>	0	5	Multi (ATEX, IEC, ETLc)			
0	0	Not Applicable (use only when AA=02) <sup>2</sup>							
0	5	Multi (ATEX, IEC, ETLc)							



### Temperature Monitoring Module (TMM)

<b>VC-8000/TMM-AA-BB</b>									
<b>Temperature Monitoring Module (spare)</b>									
<b>AA</b> <input type="checkbox"/> <input type="checkbox"/> <b>Type</b>									
<table border="1"><tr><td>0</td><td>0</td><td>TMM</td></tr><tr><td>0</td><td>1</td><td>TMM<sub>CM</sub> (Condition Monitoring Enabled)</td></tr><tr><td>0</td><td>2</td><td>TMM<sub>CM</sub> (License Only)<sup>1</sup></td></tr></table>	0	0	TMM	0	1	TMM <sub>CM</sub> (Condition Monitoring Enabled)	0	2	TMM <sub>CM</sub> (License Only) <sup>1</sup>
0	0	TMM							
0	1	TMM <sub>CM</sub> (Condition Monitoring Enabled)							
0	2	TMM <sub>CM</sub> (License Only) <sup>1</sup>							
<b>BB</b> <input type="checkbox"/> <input type="checkbox"/> <b>Agency Approvals</b>									
<table border="1"><tr><td>0</td><td>0</td><td>Not Applicable (use only when AA=02)<sup>2</sup></td></tr><tr><td>0</td><td>5</td><td>Multi (ATEX, IEC, ETLc)</td></tr></table>	0	0	Not Applicable (use only when AA=02) <sup>2</sup>	0	5	Multi (ATEX, IEC, ETLc)			
0	0	Not Applicable (use only when AA=02) <sup>2</sup>							
0	5	Multi (ATEX, IEC, ETLc)							



#### UMM/TMM NOTES:

Used only when upgrading existing field-mounted modules to CM ENABLED versions. Upgrade must be performed by an authorized Brüel & Kjær Vibro service provider and requires special firmware programming tools.

- Specify BB=00 only when AA=02 (license only). Agency approvals pertain to the hardware itself, not the presence or absence of CM ENABLED features. Approvals (or absence thereof) are provided at time the hardware modules are supplied and may not be altered in the field.

### Blank Slot Covers

All unused rack slots ship with blank covers installed and do not need to be ordered separately. Use the part number below only for spares or replacements.

<b>100367-00</b>
<b>SETPOINT blank faceplate for unused slots</b>



# Wiring and Outline Diagrams

Dim.	16P Rack	8P Rack	4P Rack
A	10.47" (266 mm)	Same as 16P	Not applicable <sup>3</sup>
B	5.16" (131 mm)	Same as 16P	Not applicable <sup>3</sup>
C	7.50" (191 mm)	Same as 16P	Not applicable <sup>3</sup>
D	2.82" (72 mm)	Same as 16P	Not applicable <sup>3</sup>
E	6.80" (173 mm)	Same as 16P	Not applicable <sup>3</sup>
F	19.00" (483 mm)	11.00" (279 mm)	7.00" (178 mm)
G	18.31" (465 mm)	10.31" (262 mm)	6.31" (160 mm)
H	16.32" (415 mm)	8.32" (211 mm)	4.32" (110 mm)
J	9.06" (230 mm)	Same as 16P	Same as 16P
K	7.50" (191 mm)	Same as 16P	Same as 16P
L <sup>1,2,3</sup>	2.95" (75 mm)	Same as 16P	See note 3
M	8.56" (217 mm)	Same as 16P	Same as 16P
N	16.50" (419 mm)	8.50" (216 mm)	4.50" (114 mm)
P	0.32" (8 mm)	Same as 16P	Same as 16P
R	9.06" (230 mm)	Same as 16P	Same as 16P

**NOTES:**

1. L dimension assumes recessed-style mounting brackets (used with optional faceplate). Racks supplied without a faceplate use flush-mount brackets (L=0). The captive screws used to retain modules in their slots will protrude by amount shown (dimension P). Total system depth when flush-mount brackets are used is dimension M+P.
2. Total system depth when optional locking faceplate is fitted to front of rack is L + M + 1.41" (36mm). Faceplate thickness (1.41") includes hinge and keylock/BNC connector protrusions.
3. Quarter rack not available with faceplate and uses only flush-mount brackets (L=0). Total system depth is M+P.



**FACEPLATE**

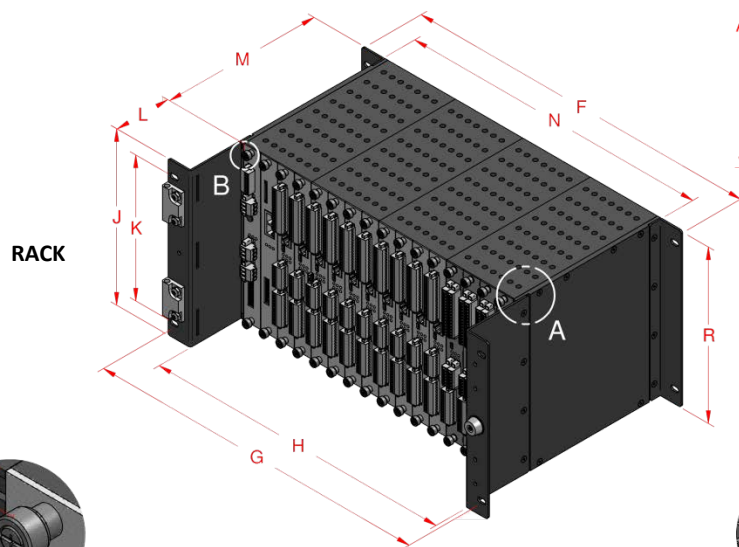

**RACK**

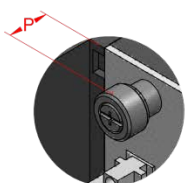

**DETAIL B**

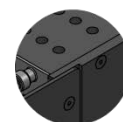

**DETAIL A**

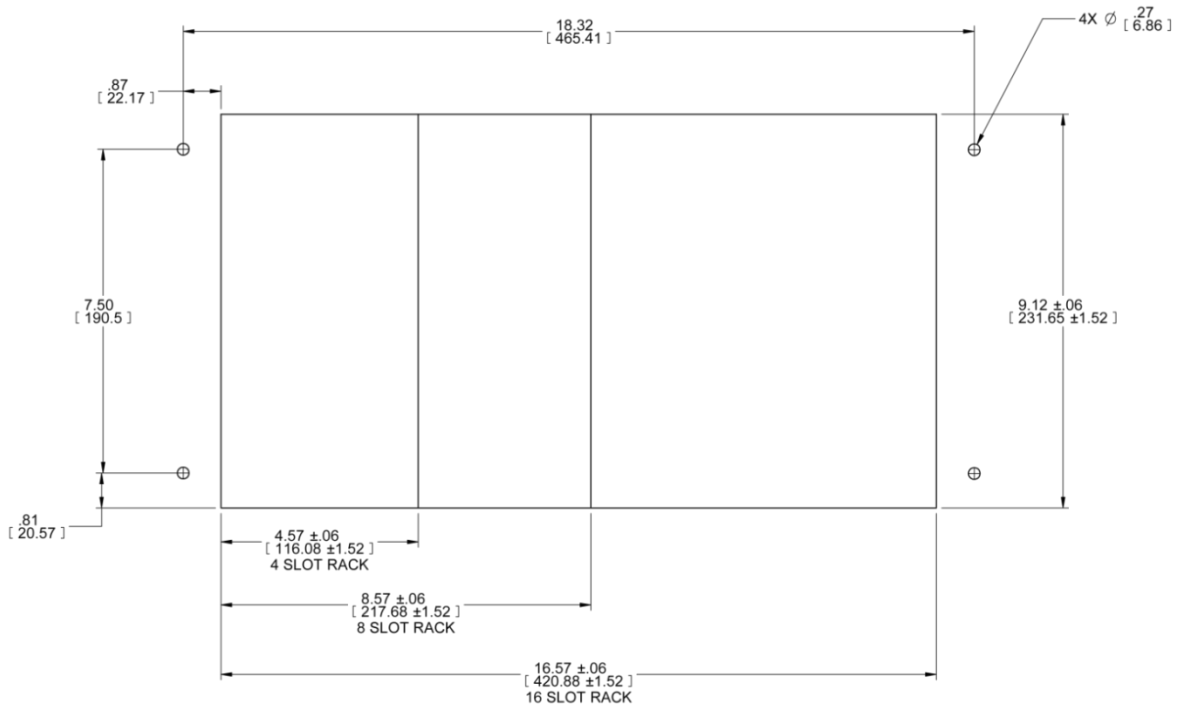
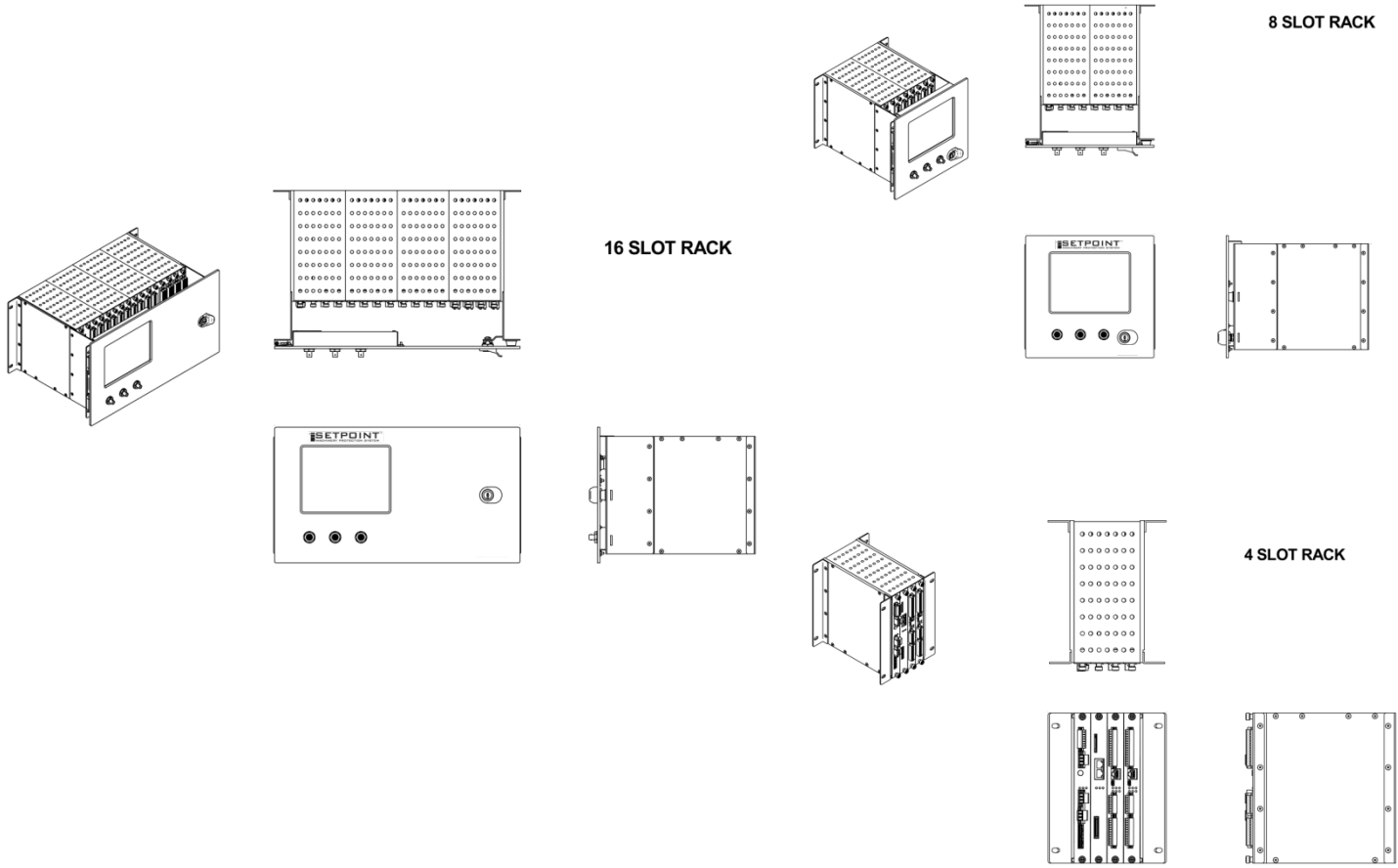

**PANEL CUTOUT DIMENSIONS IN INCHES (MM)**

### Bulkhead Mounting Style

Rear of rack mounts flush to wall or panel using flush-mount brackets. Front of rack may use optional faceplate with or without touchscreen display (for clarity, faceplate and display not shown here). When faceplate is installed it is supported on front of rack using two recessed rack brackets (shown). Faceplate is hinged to allow easy maintenance access.

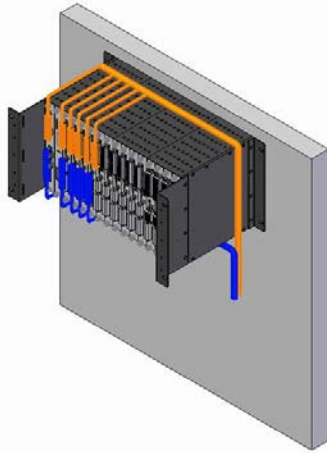

### 19" EIA Mounting Style (Recessed)

Rack mounts onto standard EIA 19" rails and is supported by two recessed brackets, allowing all wiring to be recessed. Optional lockable faceplate and touchscreen display (not shown) may be installed over front to conceal opening. Faceplate is hinged to allow easy maintenance access. Modules can also insert from rear of rack if desired and faceplate/display on front. Specify VC-8000/RCK option AA=13 when ordering.

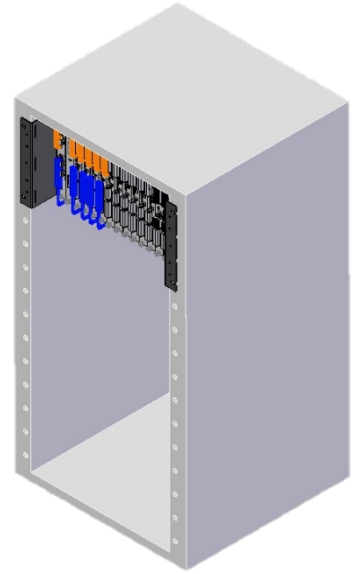

### Panel Cutout Mounting Style

Rack mounts into rectangular cutout and is supported by recessed or flush brackets. Two recessed brackets (standard) are shown here, allowing all wiring to be recessed behind the cutout. When recessed brackets are used, optional lockable faceplate and touchscreen display (not shown) may be installed over front to conceal opening. Faceplate is hinged to allow easy maintenance access. Modules can also insert from rear of rack if desired and faceplate/display on front. Specify VC-8000/RCK option AA=11 when ordering.

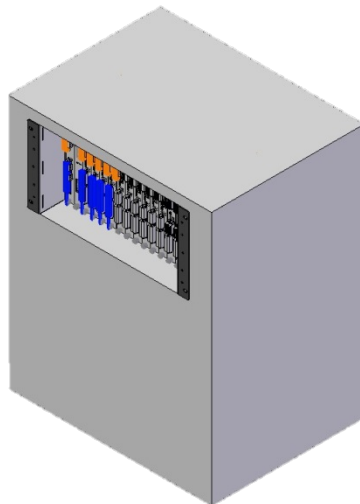

### 19" EIA Mounting Style (Flush)

Rack mounts onto standard EIA 19" rails and is supported by two flush brackets. Wiring is not recessed and assumes that the optional faceplate and display will not be installed.

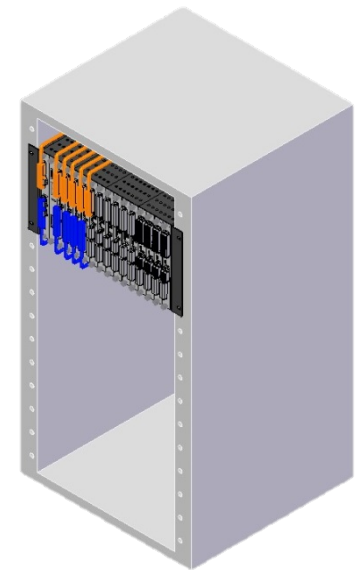

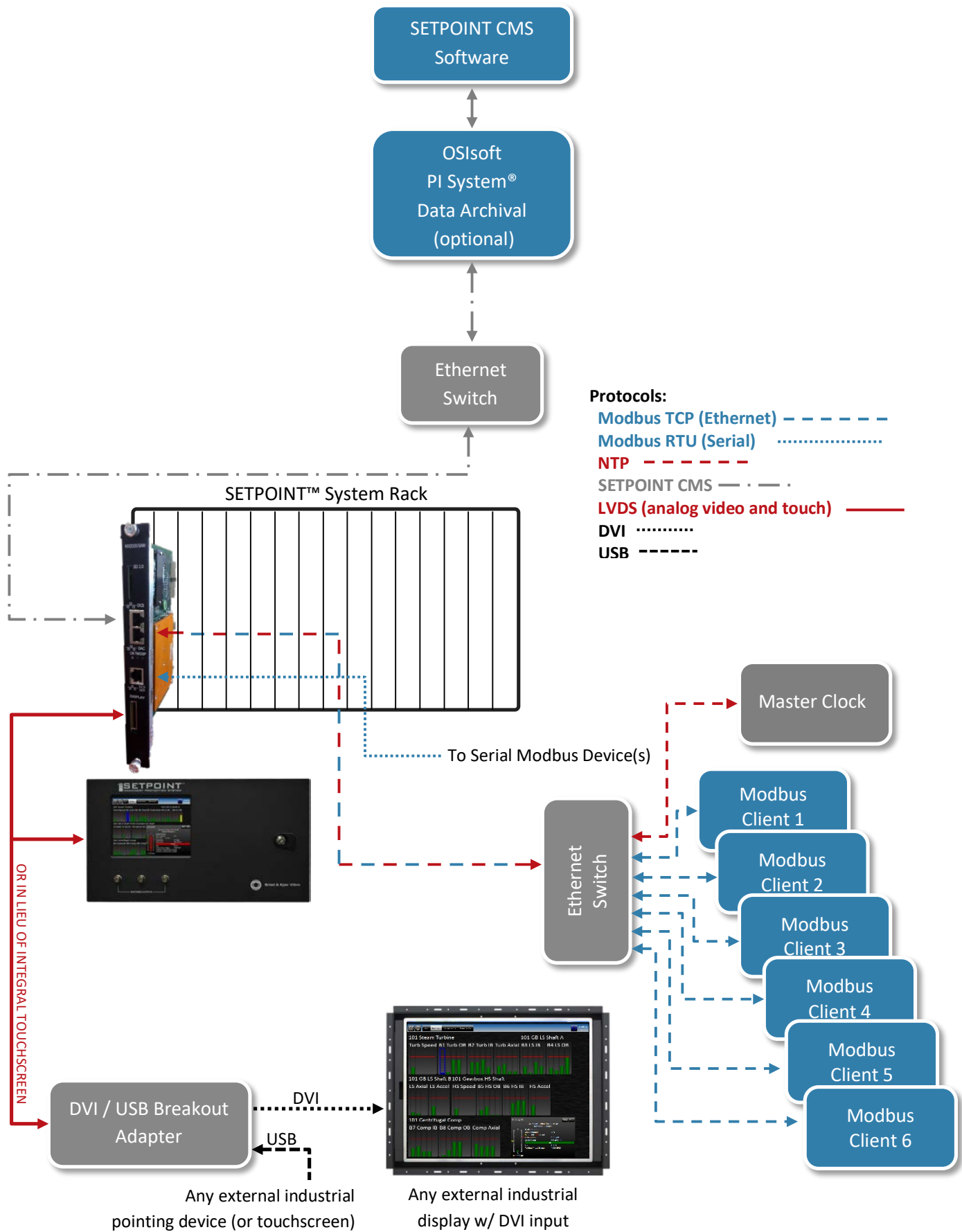

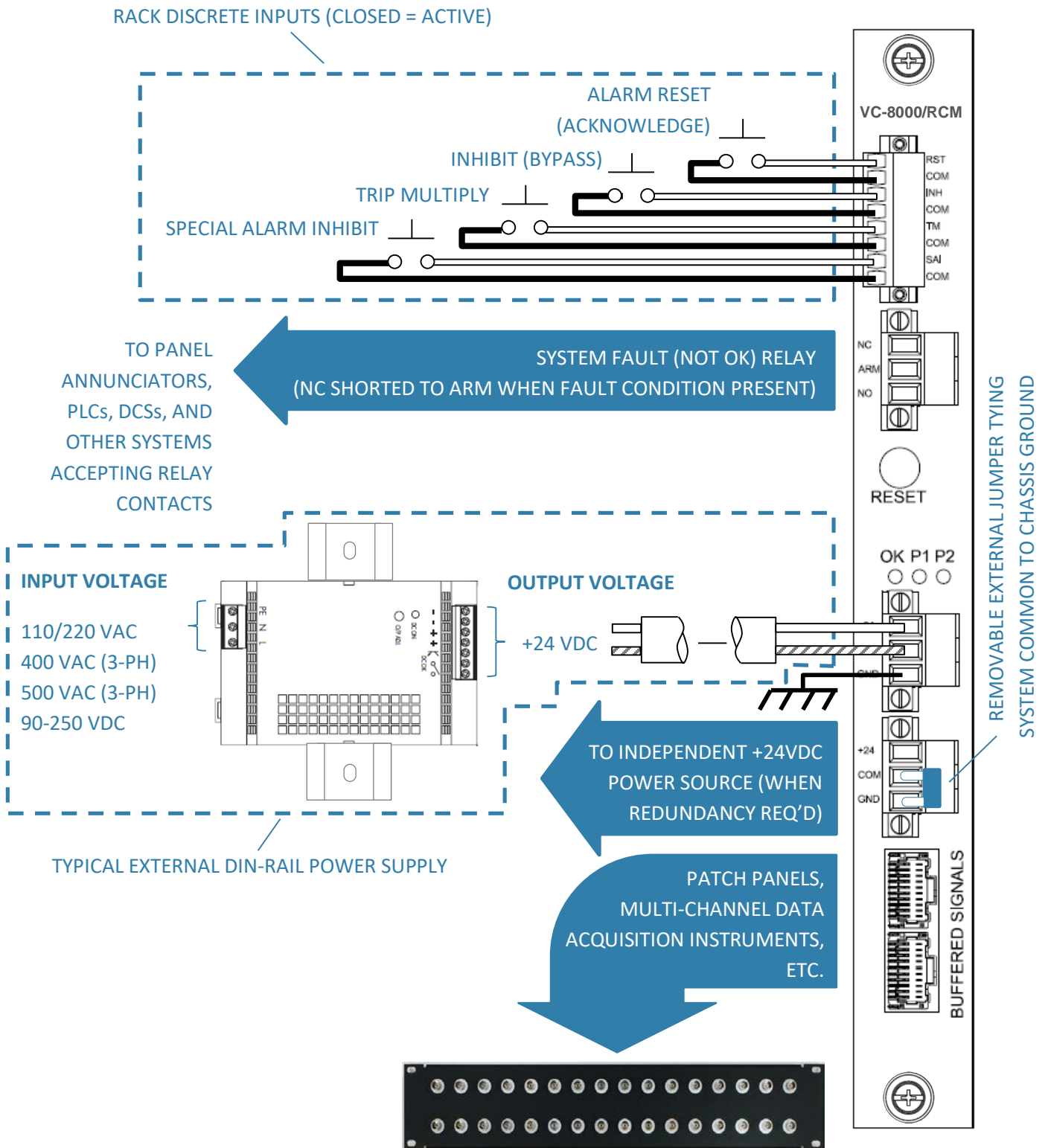



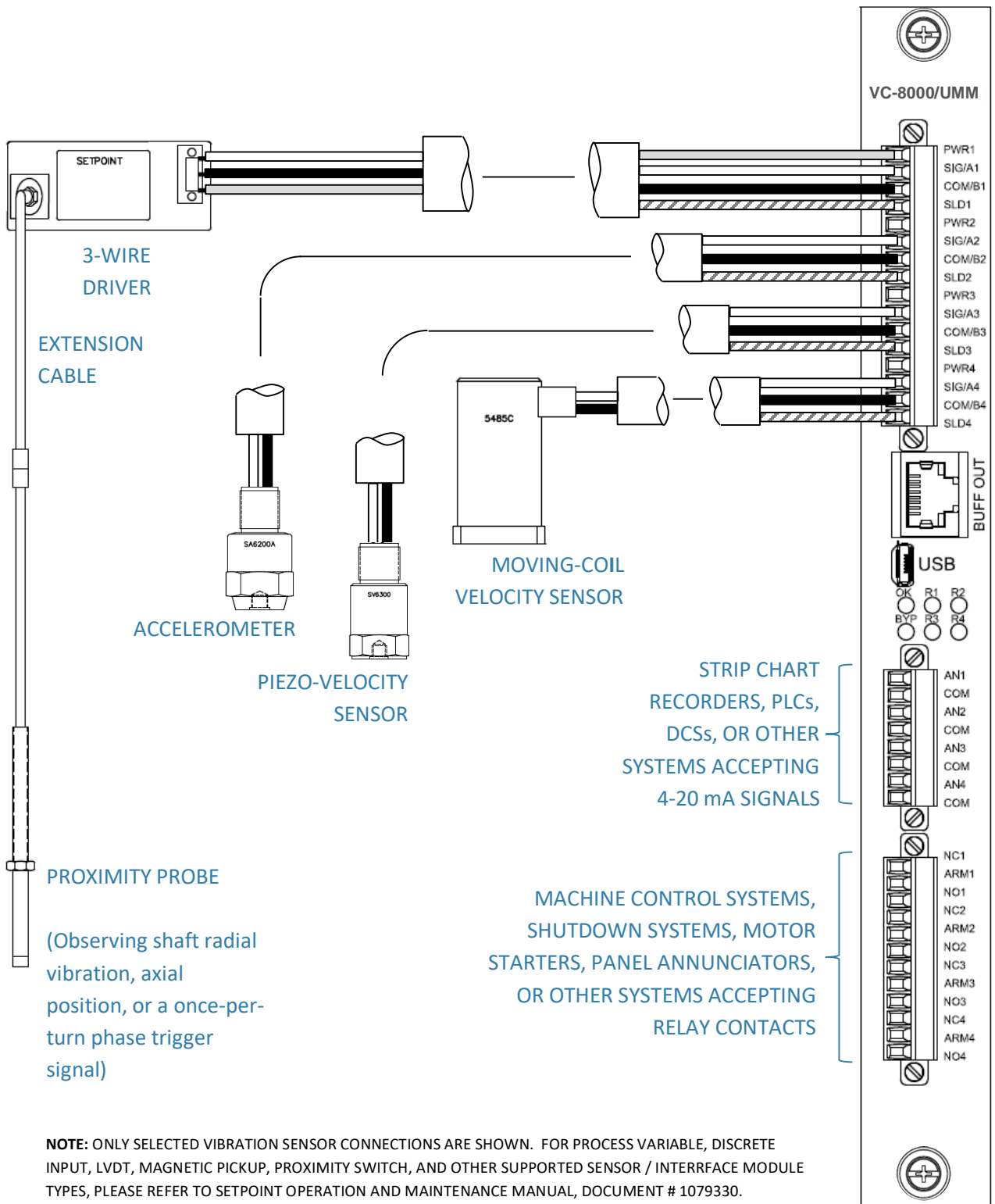

TYPICAL  
4-WIRE RTD



TYPICAL  
3-WIRE RTD



TYPICAL  
2-WIRE RTD

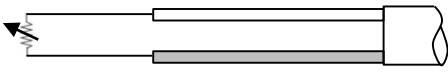

TYPICAL UNGROUNDED  
THERMOCOUPLE TIP

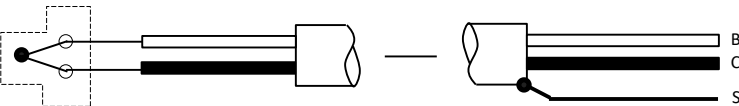

TYPICAL GROUNDED  
THERMOCOUPLE TIP

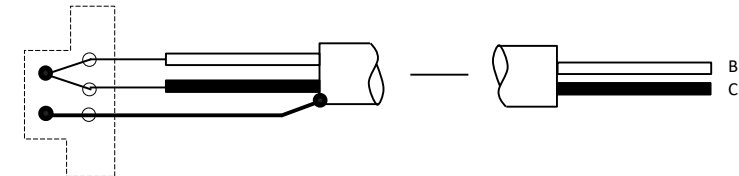

STRIP CHART RECORDERS, PLCs, DCSs,  
OR OTHER SYSTEMS ACCEPTING  
4-20 mA SIGNALS

MACHINE CONTROL SYSTEMS,  
SHUTDOWN SYSTEMS, MOTOR  
STARTERS, PANEL ANNUNCIATORS,  
OR OTHER SYSTEMS ACCEPTING  
RELAY CONTACTS

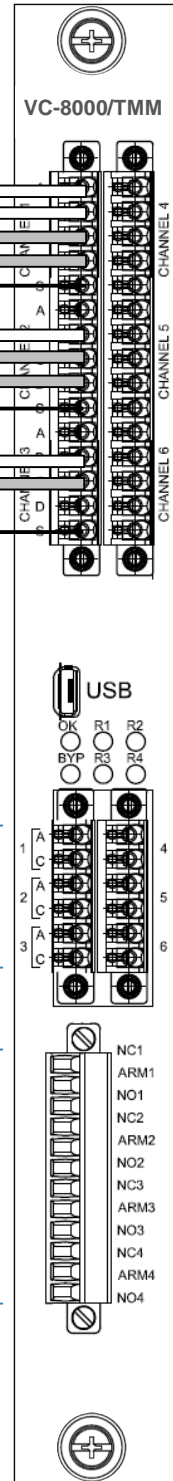

**NOTE:** ONLY TEMPERATURE INPUTS ARE SHOWN. FOR PROCESS VARIABLE INPUTS, PLEASE REFER TO SETPOINT OPERATION AND MAINTENANCE MANUAL, DOCUMENT # 1079330.

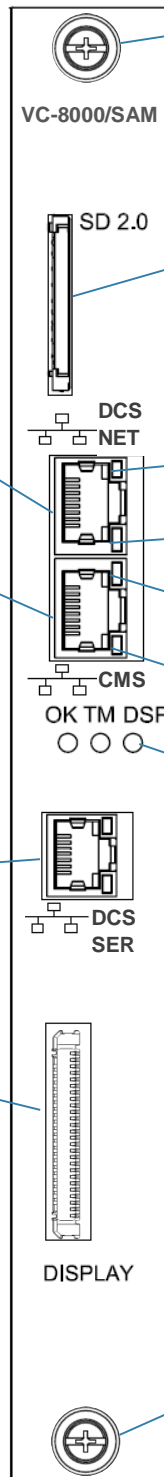

Industry-standard MODBUS® TCP/IP communications via 10/100 BASE-T for integration with plant and machinery control systems, SCADA systems, and other control and automation platforms. NTP support for clock synchronization.

10/100/1000 BASE-T Gigabit communications using an industry-first open protocol for easy access by process historian and condition monitoring software. Native connectivity to OSIsoft's PI® System.

MODBUS® RTU port; same dataset as TCP/IP port, but uses RS-232, RS-422, or RS-485 serial communications.

Optional 8.4" color touchscreen display interface. Allows display to be located anywhere within 3 m (10 feet) of SETPOINT rack. A special DVI adapter mounted external to the rack is also available, allowing larger external monitors to be used in lieu of the rack's 8.4" integral touchscreen.

Captive thumbscrew for securing SAM in SETPOINT rack slot.

Removable 32GB SD card provides one month of storage for the same data as streamed from the CMS port. When an optional solid-state hard drive is supplied in the SAM, up to one full year of data can be stored.

DCS Ethernet Link Present LED

DCS Ethernet Link Activity LED

CMS Link Present LED

CMS Link Activity LED

MODULE OK, TRIP MULTIPLY, and DISPLAY COMMUNICATIONS OK status LEDs.

Captive thumbscrew for securing SAM in SETPOINT rack slot.

Discrete inputs for invoking rack-wide functions:

- Alarm Reset (Acknowledge)
- Rack Inhibit (Bypass)
- Trip Multiply
- Special Alarm Inhibit

Dry contact or TTL-compatible active when pulled to common or TTL zero.

Local Alarm Reset (Acknowledge) Pushbutton. Performs same function as when RST and COM discrete input terminals are shorted.

Primary/Secondary +24 Vdc (nominal) power source connections. Power 2 is on top, Power 1 is on bottom (labels are visible behind connectors).

Captive thumbscrew for securing RCM in SETPOINT rack slot.

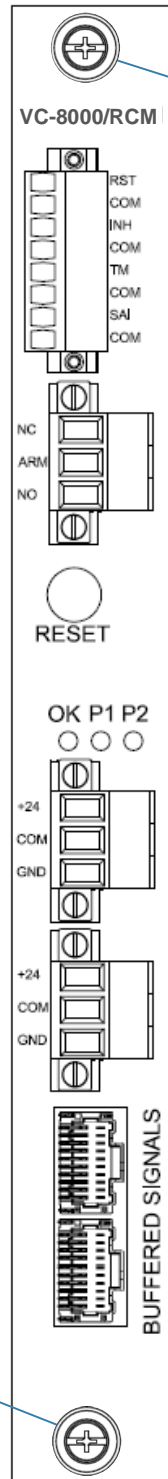

Captive thumbscrew for securing RCM in SETPOINT rack slot.

System Fault (i.e. NOT OK) Relay.

SYSTEM OK, Power 1, and Power 2 LEDs. SYSTEM OK LED is green when no faults are present. P1 is green when supply 1 detected and within specs. P2 is green when supply 2 detected and within specs.

Buffered transducer outputs for all rack UMM channels (up to 56). Intended primarily for wiring to permanent patch panels or multi-channel data acquisition instruments.

Input connections for all module channels. Connectors are removable to facilitate ease of wiring.

RJ45 receptacle with buffered output signals for channels 1-4 on individual pins.

OK, BYPASS, and Relay LEDs

4-20 mA proportional analog output connections for all channels. Connectors are removable to facilitate ease of wiring.

Mechanical relay output connections for relays 1-4. Connector is removable to facilitate ease of wiring.

Captive thumbscrews for securing modules in SETPOINT rack slots.

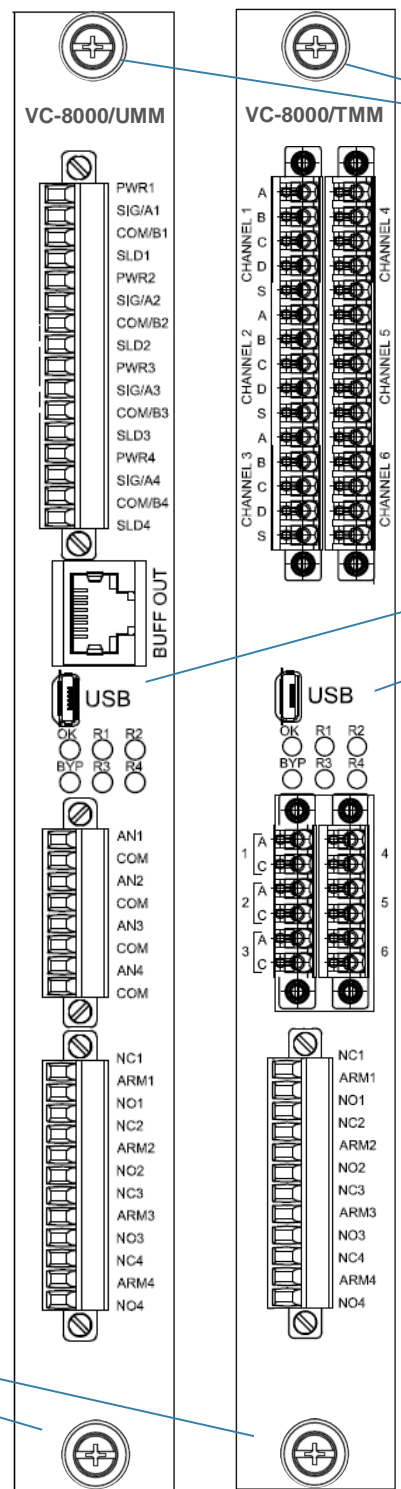

Captive thumbscrews for securing modules in SETPOINT rack slots.

Mini-B USB receptacles for connection to SETPOINT configuration software via USB cable.

PCM may reside in any rack slot 1-16.

Captive thumbscrew for securing PCM in SETPOINT rack slot.

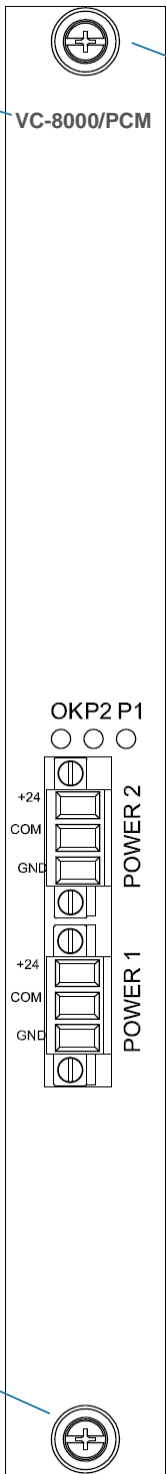

Primary/Secondary +24 Vdc (nominal) power source connections. Power 2 is on top, Power 1 is on bottom (labels are visible behind connectors).

OK, Power 1, and Power 2 LEDs. OK LED is green when no faults are present on the PCM. P1 is green when supply 1 detected and within specs. P2 is green when supply 2 detected and within specs.

Captive thumbscrew for securing PCM in SETPOINT rack slot.

### Redundant Power Configuration 1: RCM Only, Separate Power Supplies

Failure Mode	Coverage
RCM Failure	✗
PCM Failure	N/A
P1 Failure	✓
P2 Failure	✓
RCM + P1 Failure	✗
RCM + P2 Failure	✗
PCM + P1 Failure	N/A
PCM + P2 Failure	N/A
RCM + PCM Failure	N/A
P1 + P2 Failure	✗

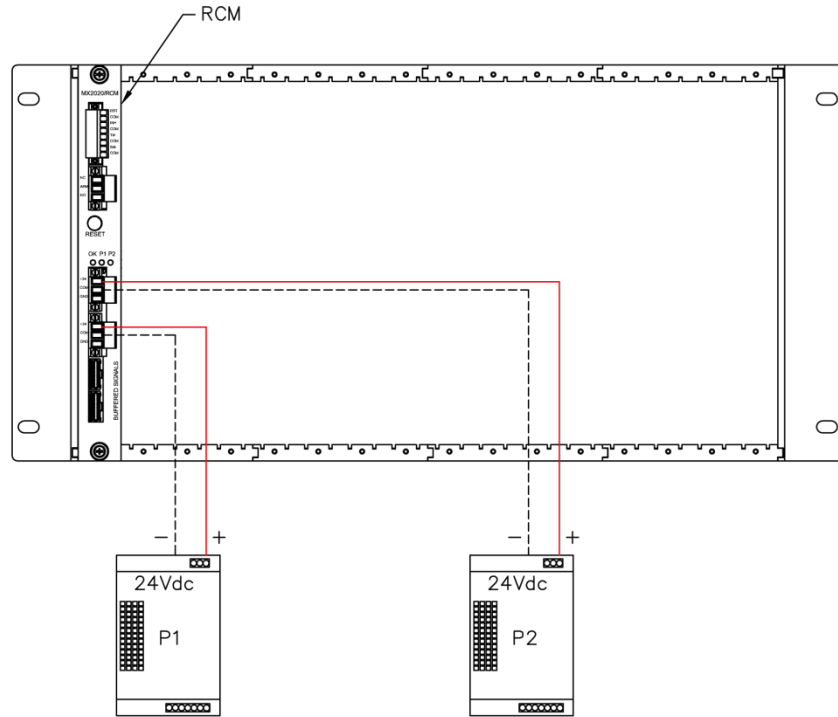

### Redundant Power Configuration 2: RCM and PCM, Separate Power Supplies

Failure Mode	Coverage
RCM Failure	✓
PCM Failure	✓
P1 Failure	✓
P2 Failure	✓
RCM + P1 Failure	✓
RCM + P2 Failure	✗
PCM + P1 Failure	✗
PCM + P2 Failure	✓
RCM + PCM Failure	✗
P1 + P2 Failure	✗

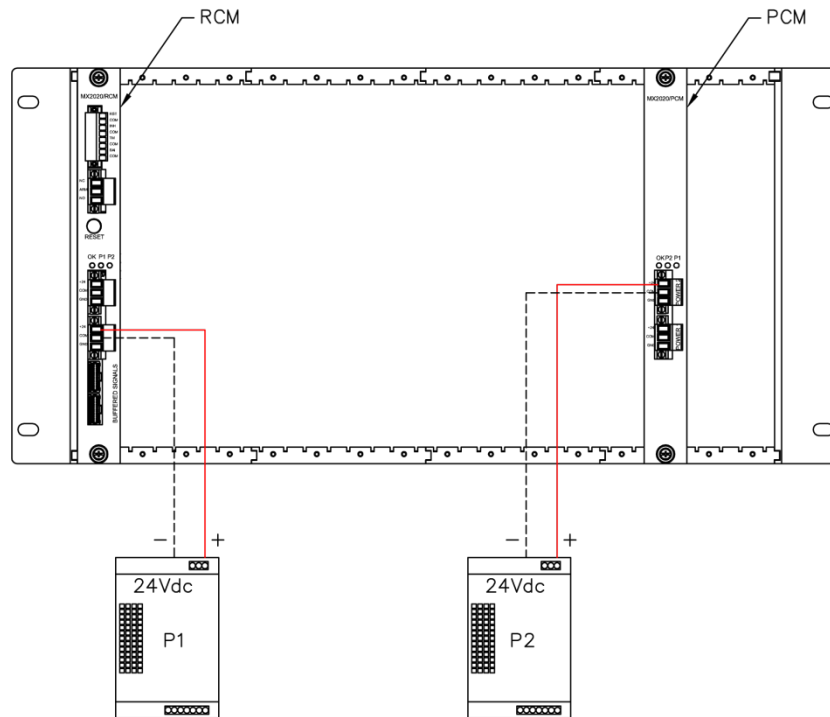

### Redundant Power Configuration 3: RCM and PCM, Shared Power Supplies

Failure Mode	Coverage
RCM Failure	✓
PCM Failure	✓
P1 Failure	✓
P2 Failure	✓
RCM + P1 Failure	✓
RCM + P2 Failure	✓
PCM + P1 Failure	✓
PCM + P2 Failure	✓
RCM + PCM Failure	✗
P1 + P2 Failure	✗

**NOTE:** External fuses required as shown to limit current in each branch to 10A.

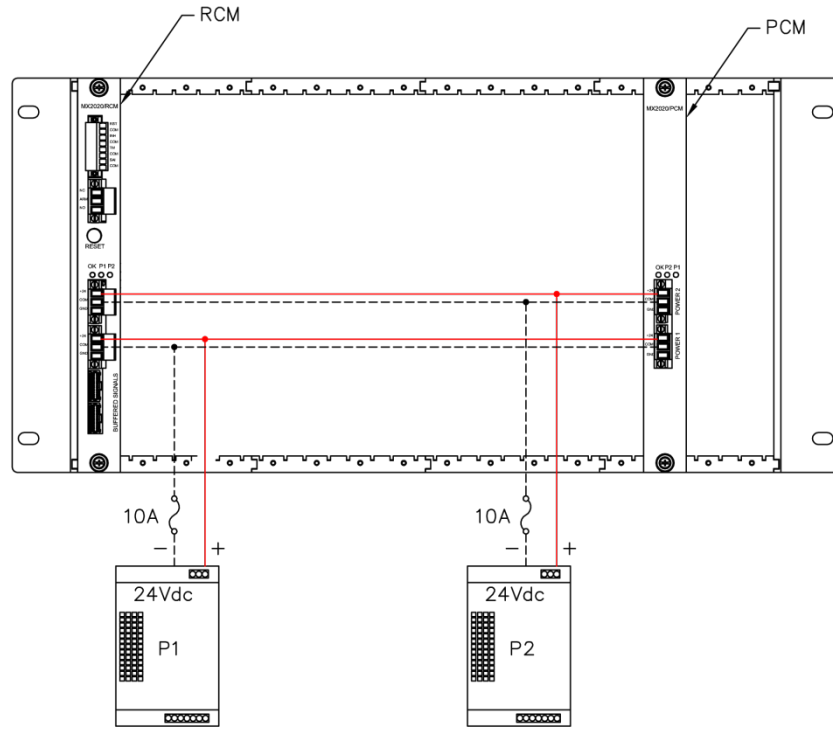

**Brüel & Kjær Vibro**

#### BK Vibro America, Inc

2243 Park Place, Suite A

Minden, NV 89423 USA

775.552.3110

www.bkvibro.com

info@setpointvibration.com

Trademarks used herein are the property of their respective owners.

Data and specifications subject to change without notice.

© 2011 - 2017